

# Installation & Operation Manual

## **Ar-Mite™ MT3750 Series Variable Area Flowmeters**

**BROOKS®**  
INSTRUMENT

*Beyond Measure*

## Essential Instructions Read before proceeding!

Brooks Instrument designs, manufactures and tests its products to meet many national and international standards. These products must be properly installed, operated and maintained to ensure they continue to operate within their normal specifications. The following instructions must be adhered to and integrated into your safety program when installing, operating and maintaining Brooks Instrument products.

- To ensure proper performance, use qualified personnel to install, operate, update, program and maintain the product.
- Read all instructions prior to installing, operating and servicing the product. If this instruction manual is not the correct manual, please see back cover for local sales office contact information. Save this instruction manual for future reference.

**▲ WARNING: Do not operate this instrument in excess of the specifications listed in the Instruction and Operation Manual. Failure to heed this warning can result in serious personal injury and / or damage to the equipment.**

- If you do not understand any of the instructions, contact your Brooks Instrument representative for clarification.
- Follow all warnings, cautions and instructions marked on and supplied with the product.

**▲ WARNING: Prior to installation ensure this instrument has the required approval ratings to meet local and national codes. Failure to heed this warning can result in serious personal injury and / or damage to the equipment.**

- Install your equipment as specified in the installation instructions of the appropriate instruction manual and per applicable local and national codes. Connect all products to the proper electrical and pressure sources.
- Operation: (1) Slowly initiate flow into the system. Open process valves slowly to avoid flow surges. (2) Check for leaks around the flow meter inlet and outlet connections. If no leaks are present, bring the system up to the operating pressure.
- Please make sure that the process line pressure is removed prior to service. When replacement parts are required, ensure that qualified people use replacement parts specified by Brooks Instrument. Unauthorized parts and procedures can affect the product's performance and place the safe operation of your process at risk. Look-alike substitutions may result in fire, electrical hazards or improper operation.
- Ensure that all equipment doors are closed and protective covers are in place to prevent electrical shock and personal injury, except when maintenance is being performed by qualified persons.

**▲ WARNING: For liquid flow devices, if the inlet and outlet valves adjacent to the devices are to be closed for any reason, the devices must be completely drained. Failure to do so may result in thermal expansion of the liquid that can rupture the device and may cause personal injury.**

### European Pressure Equipment Directive (PED)

All pressure equipment with an internal pressure greater than 0.5 bar (g) and a size larger than 25mm or 1" (inch) falls under the Pressure Equipment Directive (PED).

- The Specifications Section of this manual contains instructions related to the PED directive.
- Products described in this manual are in compliance with EN directive 2014/34/EU.
- All Brooks Instrument Flowmeters fall under fluid group 1.
- Products larger than 25mm or 1" (inch) are in compliance with PED category I, II or III.
- Products of 25mm or 1" (inch) or smaller are Sound Engineering Practice (SEP).

### European Electromagnetic Compatibility (EMC)

The Brooks Instrument (electric/electronic) equipment bearing the CE mark has been successfully tested to the regulations of the Electro Magnetic Compatibility (EMC directive 2014/30/EU).

Special attention however is required when selecting the signal cable to be used with CE marked equipment.

**Quality of the signal cable, cable glands and connectors:**

Brooks Instrument supplies high quality cable(s) which meets the specifications for CE certification.

If you provide your own signal cable you should use a cable which is overall completely screened with a 100% shield.

"D" or "Circular" type connectors used should be shielded with a metal shield. If applicable, metal cable glands must be used providing cable screen clamping.

The cable screen should be connected to the metal shell or gland and shielded at both ends over 360 Degrees.

The shield should be terminated to an earth ground.

Card Edge Connectors are standard non-metallic. The cables used must be screened with 100% shield to comply with CE certification.

The shield should be terminated to an earth ground.

For pin configuration : Please refer to the enclosed Instruction Manual.

### ESD (Electrostatic Discharge)

**▲ CAUTION: This instrument contains electronic components that are susceptible to damage by static electricity. Proper handling procedures must be observed during the removal, installation or other handling of internal circuit boards or devices.**

**Handling Procedure:**

1. Power to unit must be removed.
2. Personnel must be grounded, via a wrist strap or other safe, suitable means before any printed circuit card or other internal device is installed, removed or adjusted.
3. Printed circuit cards must be transported in a conductive container. Boards must not be removed from protective enclosure until immediately before installation. Removed boards must immediately be placed in protective container for transport, storage or return to factory.

**Comments**

This instrument is not unique in its content of ESD (electrostatic discharge) sensitive components. Most modern electronic designs contain components that utilize metal oxide technology (NMOS, SMOS, etc.). Experience has proven that even small amounts of static electricity can damage or destroy these devices. Damaged components, even though they appear to function properly, exhibit early failure.

**Introduction Section 1**

Description.....	1
Specifications .....	1
Optional Equipment.....	4

**Installation Section 2**

General.....	12
Receipt of Equipment .....	12
Recommended Storage Practice.....	12
Return Shipment.....	12
Transit Precautions.....	13
Removal From Storage .....	13
Installation of Flowmeter.....	13
Installation of Inductive Alarm.....	13
Installation of Reed Switch Alarm .....	16
Installation of Transmitter .....	19

**Operation Section 3**

Operating Procedure .....	23
Operation of Inductive Alarm .....	23
Operation of Transmitter.....	23
Operation of Reed Switch Alarm .....	24

**Maintenance Section 4**

General.....	27
Service Information.....	27
On Site Adjustment/Calibration.....	27

**Parts List Section 5**

General.....	29
--------------	----

**Essential Instructions Section A**

Essential Instructions.....	31
-----------------------------	----

<b>Warranty, Local Sales/Service Contact Information .....</b>	<b>Back Cover</b>
--	-------------------

**Tables**

1-1	MT3750C Specifications.....	2
1-2	MT3750C Capacities .....	2
1-3	MT3750C Pressure Ratings in PSIG (BarG) .....	3
1-4	MT3750C Fluid Temperature at Ambient Temperature .....	3
1-5	Temperature Ratings for Elastomer Materials .....	3
1-6	Approvals - MT3750C.....	3
1-7	Certifications - MT3750C with Transmitter.....	4
1-8	Certifications - MT3750C with Reed Switch Alarm .....	6
1-9	Certifications - MT3750C with Inductive Alarm.....	7
3-1	Interior Label MT3750 Ar-Mite Alarm .....	25

**Figures**

1-1	Model MT3750C with Transmitter.....	4
1-2	Power Supply vs. Maximum Load Resistance.....	5
1-3	Transmitter Wiring Diagram .....	5
1-4	Model MT3750C with Reed Switch Alarm .....	6
1-5	Reed Switch Wiring Diagram.....	6
1-6	Model MT3750C with Inductive Alarm .....	7
1-7	Dimensions for MT3750C Threaded Connections Metal Tube Flowmeter with Indicator .....	8
1-8	Dimensions for MT3750C Threaded Connections with Transmitter or Inductive Alarm .....	9
1-9	Dimensions for MT3750C Threaded Connections with Reed Switch Alarm.....	10
1-10	Dimensions for MT3750C Panel Mounting .....	11
2-1	Typical Installation .....	14
2-2	Inductive Switch Wiring Diagram .....	14
2-3	Inductive Switch Wiring.....	15
2-4	Reed Switch Alarm Wiring Using IS Barriers .....	16
2-5	Reed Switch Alarm Installation Using P & F Relay Unit .....	17
2-6	Reed Switch Alarm Wiring Using P & F Relay Unit .....	17
2-7	Transmitter Wiring Diagram for I.S. Systems .....	19
2-8	Transmitter Wiring Diagram for XP Systems .....	21
2-9	Transmitter Wiring Diagram .....	22
3-1	Reed Switch Alarm .....	26
5-1	Model MT3750 Exploded View .....	30

## Description

The Brooks® Ar-Mite™ is a reliable, low flow metal tube flowmeter with 316L stainless steel wetted parts. The magnetically coupled indicator provides a highly reliable method of indication. This model is a practical and economical approach to low flow rate indication for high pressure and difficult to handle fluids. Optional accessories include 4-20 mA output, Needle Valve, Flow Controllers and Alarms.

## Specifications

### **WARNING**

**Do not operate this instrument in excess of the specifications listed below. Failure to heed this warning can result in serious personal injury and/or damage to the equipment.**

### **CAUTION**

**It is the user's responsibility to select and approve all materials of construction. Careful attention to metallurgy, engineered materials and elastomeric materials is critical to safe operation.**

### **Pressure Equipment Directive (PED) 2014/08/EU**

Flowmeters mentioned in this instruction manual are Sound Engineering Practice (SEP).

- Pressurized materials are manufactured in compliance with material standard ASTM.
- Applied welding method is in accordance with ASME IX / EN 287-288.
- Flowmeters are designed in accordance with ASME B31.3 and ASME B31.1
- Admissible maximum temperatures and pressure are stated further in this manual.

Table 1-1 MT3750C Specifications

Specifications	MT3750C
Measuring Range	See Capacities Table 1-2
Rangeability	10:1 (most sizes)
Metering Tube	316L (stainless steel)
	Monel K-500
End Fittings	316L (stainless steel)
	Monel K-500
Accuracy	5%, 3%, VDI/VDE class 4, 2.5
Repeatability	1% Full Scale
Scale	Silver increments with black background - Aluminum Material (52 mm long), single or dual
Connections	1/4" to 3/4" NPT Female
	1/4", 6 mm tube compression
Floats	316L stainless steel
	Titanium Gr. II
O-rings	Viton® fluoroelastomers
	PTFE Teflon®, Buna-N, Kalrez® 4079 perfluoroelastomers, Ethylene Propylene
Protection Category	(Alarms IP65/NEMA-4X, (Transmitter) IP66/67/NEMA 4X
Indicator Housing & Cover	Die cast Aluminum (Alloy 380), epoxy paint, glass window
Maximum Fluid Temperature	204°C/400°F (Refer to Tables 1-4 & 1-5)
Maximum Fluid Pressure	1500 PSIG (100 Bar)
	4000 PSIG (276 Bar) (No valve, 1/4" NPT only)
Meter Dimensions	Refer to Figures on Pages 1-8 thru 1-11
Pressure Equipment Directive	Flowmeter complies under Sound Engineering Practices (SEP) (PED) 2014/68/EU
RoHS	Products conform to the European Restriction of Hazardous Substances (RoHS) Directive 2011/65/EU
Inductive Alarm Switches	1 or 2 inductive switches
Reed Switches	1 or 2 switches
Transmitter	4-20 mA-output
Agency Approvals	Refer to Tables 1-6 thru 1-9
Optional Equipment	Cartridge or NRS™ valves
	Integrally mounted flow controllers

Table 1-2 MT3750C Capacities

Meter Size	Flow Range					Viscosity Limit <sup>(3)</sup>	Pressure Drop	
	Water		Air <sup>(1, 2)</sup>				mBar	Inches WC
	gph	l/h	ln/h	scfh	m³n/h			
0	0.025-0.25	0.096-0.96	4.3-43	0.16-1.6	-	5	12	4.8
1	0.034-0.34	0.13-1.3	5.6-56	0.21-2.1	-	10	12	4.8
2	0.096-0.96	0.36-3.6	13.0-120	0.5-4.9	-	20	12	4.8
3	0.29-2.8	1.0-10	-	1.2-12	0.033-0.33	35	12	4.8
4	0.55-5.5	2.1-21	-	2.5-23	0.063-0.62	70	32	12.8
5	1.1-11	4.2-42	-	5.4-53	0.15-1.3	100	38	15.3
6	2.8-26	11-100	-	12-110	0.31-3.1	130	44	17.7

Notes:

- Air flows in scfh converted to 70°F and 14.7 psia when the meter is operated at 70°F and 14.7 psia.
- Air flows in m³n/h (converted to normal conditions: 0° and 1.013 bar abs) when the meter is operated at 1.013 bar abs and 20°C.
- When the viscosity of the fluid exceeds the viscosity immunity ceiling (VIC), a calculated correction is applied to account for the difference between factory calibration fluid and process fluid.

Table 1-3 MT3750C Pressure Ratings in PSIG (BarG)

Meter Type	Pressure Rating -58°F to 400°F / -50°C to 204°C
Standard Meter	1500 (100)
High Pressure Meter	4000 (276)

Table 1-4 MT3750C Fluid Temperature at Ambient Temperature

Max. Ambient Temperature		Max. Fluid Temperature per Option					
		Indicator		Alarm		Transmitter	
°F	°C	°F	°C	°F	°C	°F	°C
-58	-50	-58 to 400	-50 to 204	N/A	N/A	N/A	N/A
-20	-29	400	204	-20 to 250	-29 to 120	-20 to 180	-29 to 82
104	40	400	204	250	120	180	82
110	43	390	199	250	120	175	79
120	49	380	193	250	120	170	76
130	54	370	187	250	120	165	74
140	60	360	182	240	115	155	68
150	65	350	176	235	112	150	65

Notes:

1. Ambient temperature is limited to 150°F (65°C) maximum. Contact factory for ambient temperature > 150°F (65°C)

Table 1-5 MT3750C Temperature Ratings for Elastomer Materials

Elastomer Materials	Minimum Temperature		Maximum Temperature	
	°F	°C	°F	°C
Kalrez 4079	-58	-50	400	204
Viton A	5	-15	400	204
Teflon PTFE	-58	-50	400	204
Buna	-22	-30	250	120
Ethylene Propylene	-58	-50	250	120

Table 1-6 Approvals - MT3750C

(Reference Tables 1-7, 1-8 & 1-9 for Certifications with Transmitter, Reed Switch Alarm and Inductive Alarm)

Approvals	Mark	Meter Options				Standards/Directives/Marking	Declaration/Certificate
		Mechanical	Transmitter	Inductive Switch Alarm	Reed Switch Alarm		
EU Declaration of Conformity	CE	✓	✓	✓	✓	EMC Directive (2014/30/EU)	Declaration
		✓	✓	✓	✓	RoHS Directive (2011/65/EU)	Declaration
		✓	✓	✓	✓	Pressure Equipment Directive (2014/68/EU)	Declaration - SEP
CRN		✓	✓	✓	✓	ASME B31.1 & ASME B31.3	CRN
IP66/67 & NEMA 4X		✓				IEC 60529 & NEMA 250-2014	Declaration
IP66/67			✓			IEC 60529	DEKRA Certificate/ UL
IP65				✓		IEC 60529	DEKRA Certificate
Type 4X			✓	✓	✓	CSA	CSA / UL Certificate
Explosion safety "Constructional safety (c)"	ATEX Ex	✓				II2G Ex h IIC T6...T3 Gb II2D Ex h IIC T200°C Db	MBID 022
<p><b>Special conditions for safe use:</b> Enclosure contains glass &amp; painted aluminum parts. If it is mounted in an area where the use of category 2G or 2D apparatus is required, it must be installed such that ignition source due to propagating brush discharge sparks are excluded.</p> <p>The actual maximum surface temperature of the equipment depends not on the equipment itself, but on operating conditions of the process fluid/gas flowing through the equipment. The equipment by itself does not generate heat. Due to this reason the temperature class is marked as a range. The maximum permitted ambient and process temperature limits can be found in the operating instructions.</p> <p>At start up especially for gas applications, ensure that the pressure is gradually increased through the piping system. A sudden pressure spike situation may result in a fast movement of the float within the VA flow meter &amp; the float may hit hard against the float stop.</p> <p>Supply grounding connection by the process connections or earthing terminal.</p>							

Optional Equipment



**Transmitter**

The transmitter provides accurate magnet angle detection and conversion to a 4 - 20 mA industry standard output signal, based on the position of a float assembly in the flowmeter. This rugged, compact, microprocessor-driven device is capable of providing accurate flow information to your external support systems. The patented magnetic sensor with automatic gain control enables an extremely high dynamic capture range without sacrificing accuracy. Reference Transmitter Wiring Diagram Figure 1-3

Figure 1-1 Model MT3750C with Transmitter

Table 1-7 Approvals - MT3750C with Transmitter

Approvals	Mark	Meter Options				Standards/Directives/Marking	Declaration/Certificate
		Mechanical	Transmitter	Inductive Switch Alarm	Reed Switch Alarm		
Explosion safety "Flame Proof"	ATEX 		✓			II 2 G Ex d IIC T6 II 2 D Ex tD A 21 IP66 T 85°C EN 60079-0:2006, EN 60079-1:2004, EN 61241-0:2006, EN 61241:2004 <b>Special conditions for safe use:</b> For information regarding the dimension of the flameproof joints the manufacturer shall be contacted.	KEMA 01ATEX2174
	IECEX		✓			EX d IIC T6 IEC 60079-0:2004 IEC 60079-1:2003 <b>Special conditions for safe use:</b> For information regarding the dimension of the flameproof joints the manufacturer shall be contacted.	IECEX KEM 06.0049
	UL 		✓			Class I, Div.1, Groups A, B, C, and D,T6 Class II, Div.1, Groups E, F, and G Class I, Zone 1 AEx d IIC T6, Ex d IIC T6	UL File E73889
	NEPSI 		✓			Ex d IIC T6 Gb GB3836.1-2010 GB3836.2-2010	GYJ11.1638X
Explosion safety "Intrinsic Safety (ia)"	ATEX 		✓			II 2 G Ex ia IIC T6 II 2 D Ex iaD 21 IP66/IP67 T70°C, II 2 D Ex tD A21 IP66/IP67 T70°C EN 60079-0:2006, EN 60079-11:2007 EN 61241-0:2006, EN 61241-11:2006	KEMA 01ATEX1033
	IECEX		✓			Ex ia IIC T6 IEC 60079-0:2004 IEC 60079-11:1999	IECEX KEM 06.0037
	SP 		✓			Class I, II, III, Div.1, Groups A, thru G, T6 Class I, Zone 1 AEx ia IIC T6, Ex ia IIC T6	1292059
	NEPSI 		✓			Ex ia IIC T6 Gb Ex iaD 21 T70°C GB3836.1/4-2010, GB 12476.4-2010	GYJ11.1637
Explosion safety "Non-sparking (nA)"	IECEX		✓			Ex nA II T6	IECEX KEM 06.0037
	SP 		✓			Class I, Div.2, Grps A, B, C, and D; Class II Grps F and G, T6 Class I, Zone 2 AEx nA II T6, Ex nA II T6	1292059
Russia Custom Union Excessive Pressure	EAC 		✓			Custom Union including Russia "On safety of the equipment operating under excessive pressure" TR CU 032/2013	TC N RU Д-У.АУ04.В.05988
Russia Custom Union Explosion safety	EAC 		✓			Custom Union including Russia "On safety of the equipment for work in explosive environments" TR CU 012/2011 (TR CU Ex)	RU C-HU.ГБ08.В.00741



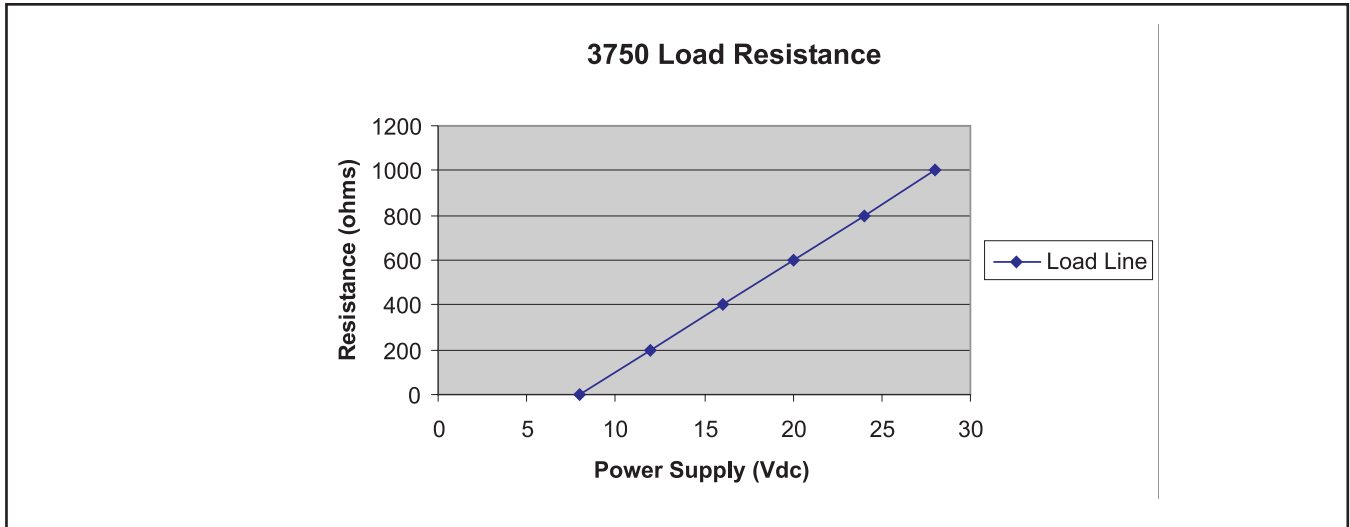

Figure 1-2 Power Supply vs. Maximum Load Resistance

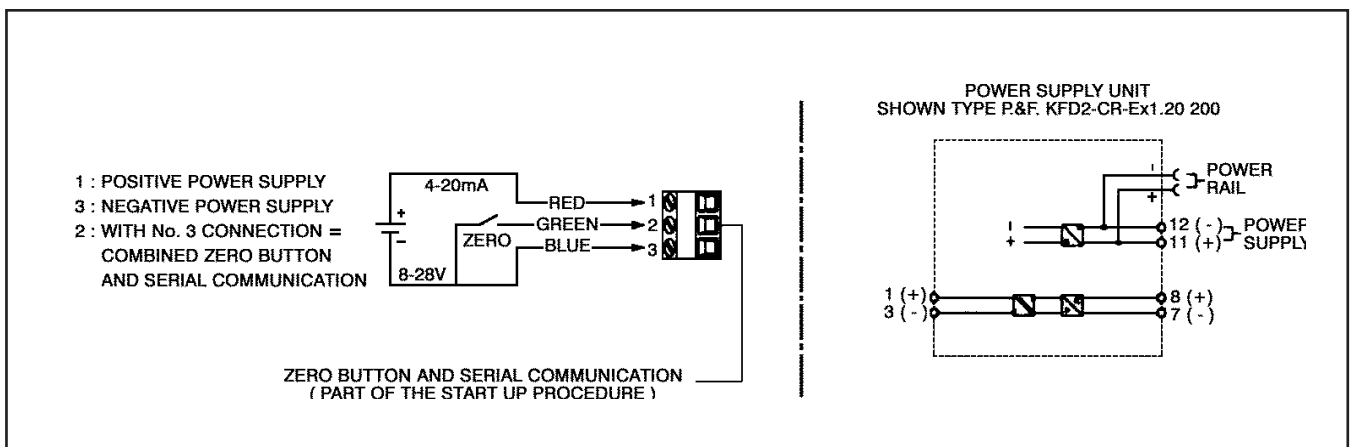

Figure 1-3 Transmitter Wiring Diagram

**CAUTION**

The transmitter is typically used with a 2 wire loop analog signal. Under normal conditions, the transmitter must always sense a static magnetic field. Failure to do this will produce an output independent of arbitrary fields like the earth's magnetic field.



Figure 1-4 Model MT3750C with Reed Switch Alarm

**Reed Switch Alarm**

Two reed switches are installed in the alarm housing to provide signaling or switching functions when a preset flow value has been reached. The reed switches provide high, low or dual setpoints and latched output over the full range. The switches are normally adjusted to the desired flow range in the factory. Modifications to the switch settings can be made in the field. Minimum setting distance between two switches is approximately 40% of the scale. (Reference Reed Switch Wiring Diagram Figure 1-5)

**Data Reed Switch**

- Maximum Voltage\* 175 Vdc, 124 Vac
- Maximum Current\* 250 mA
- Maximum Contact Rating\* 3 Watts
- (\*Maximum Switch Specifications)

**Electrical Classification**

- Non Incendive:
- Maximum Voltage 30 Vdc
- Maximum Current 100 mA
- Maximum Contact Rating 3 Watts

Table 1-8 Approvals - MT3750C With Reed Switch Alarm

Approvals	Mark	Meter Options				Standards/Directives/Marking	Declaration/Certificate
		Mechanical	Transmitter	Inductive Switch Alarm	Reed Switch Alarm		
Explosion safety "Intrinsic Safety (ia)"					✓	Class I, Div 1, Groups A, B, C and D; Class II, Groups E, F and G; Class III; Encl Type 4X IS Entity Parameters: Vmax=30Vdc, Imax=100mA, Ci=0, Li=0	1788748
Explosion safety "Non-incendive"					✓	Class I, Div 2, Groups A, B, C and D; Class II, Groups E, F and G; Class III; Encl Type 4X	1788748
Explosion safety "Intrinsic Safety (ia)"					✓	Reed Switch Alarms are classified as "Simple Apparatus" when used in Intrinsically Safe circuits. They comply with the requirements of EN60079-11 clause 5.7 – Simple apparatus.  Ambient Temperature ratings: -20° C ≤ Tamb ≤ 65° C Input parameters: Vmax = 30V, Imax = 100mA, Ci = 0µF, Li = 0µH  Special conditions for safe use: • The product should be installed by suitably trained personnel, in accordance with the applicable code of practice. • As the product has no source of internal heating, the temperature classification is dependent on the ambient air temperature. • Since part of flowmeter enclosure is made of painted aluminum, if it is mounted in group II, category 1 area, it must be installed such, that, ignition sources due to propagating brush discharge sparks are excluded	

Figure 1-5 Reed Switch Wiring Diagram

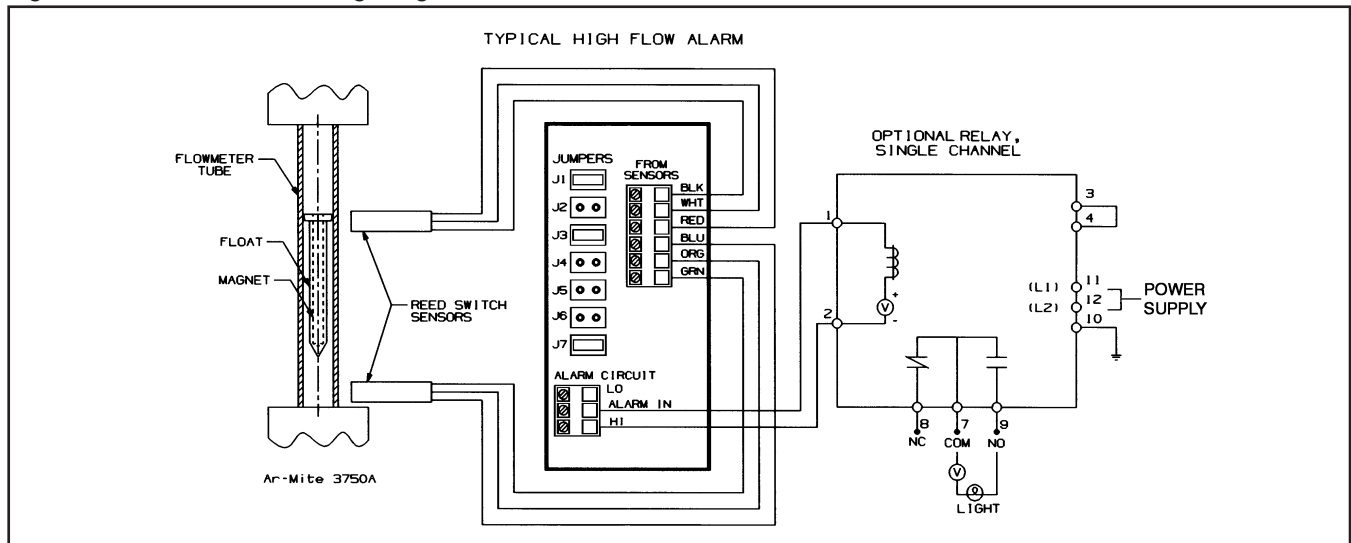



Figure 1-6 Model MT3750C with Inductive Alarm

**Limit Switches - Inductive Alarm Switch**

One or two electronic limit switches type SJ2-N can be installed in the indicator housing to allow initiation of signaling or switching functions on a preset flow value being reached. The SJ2-N limit switch operates as a slot initiator that is inductively actuated by a cam mounted to the pointer. Any flow value can be used for setting the limit value by sliding the switch along the slot in the mounting plate for the initiators. Minimum setting distance between two limit switches is approximately 50% of the scale range.

<b>Power supply</b>	<b>8 Vdc (Max. 15.5 Vdc)</b>
Current consumption	active area clear: > 3 mA
Current consumption	active area obscured: < 1 mA
Self inductance	29 µH
Self capacitance	20 nF
Max Temp	158°F (70°C)

The flow valve can be used for setting the limit value by sliding the switch along the slot in the mounting plate for the initiators. Minimum setting distance between two limit switches is approximately 50% of the scale range.

Table 1-9 Approvals - MT3750C With Inductive Alarm

Approvals	Mark	Meter Options				Standards/Directives/Marking	Declaration/Certificate
		Mechanical	Transmitter	Inductive Switch Alarm	Reed Switch Alarm		
Explosion safety "Intrinsic Safety (ia)"	ATEX 			✓		II 2 G Ex ia IIC T6 II 2 D Ex ia D 21 IP65 T75°C EN 60079-0:2006, EN 60079-11:2007 EN 61241-0:2006, EN 61241-11:2006	KEMA 02ATEX1126
	IECEX			✓		Ex ia IIC T6 Gb Ex ia IIIC T 75°C Db IP65 IEC 60079-0:2007-10 , IEC 60079-11:2006 , IEC 61241-11:2005	IECEX KEM 09.0046
				✓		Class I, II, III, Div.1, Groups A thru G, T6 Class I, Zone 0, Zone 1 AEx ia IIC, T6 Ex ia IIC T6	1379260
	NEPSI 			✓		Ex ia IIC T6 Gb GB3836.1-2010 GB3836.4-2010	GYJ11.1639
Explosion safety "Non-sparking (nA)"				✓		Class I, II, III, Div. 2, Groups A thru G, T6 Class I, Zone 2 AEx nA II, T6 Ex nA II T6	1379260
	NEPSI 			✓		Ex nA IIC T6 Gc GB3836.1:2010; GB3836.8:2003	GYJ13.1315
Russia Custom Union Excessive Pressure				✓		Custom Union including Russia "On safety of the equipment operating under excessive pressure" TR CU 032/2013	TC N RU Д- U.AY04.B.05988
Russia Custom Union Explosion safety				✓		Custom Union including Russia "On safety of the equipment for work in explosive environments" TR CU 012/2011 (TR CU Ex)	RU C-HU.ГБ08.B.00741

Figure 1-7 Dimensions for MT3750C Threaded Connections Metal Tube Flowmeter with Indicator

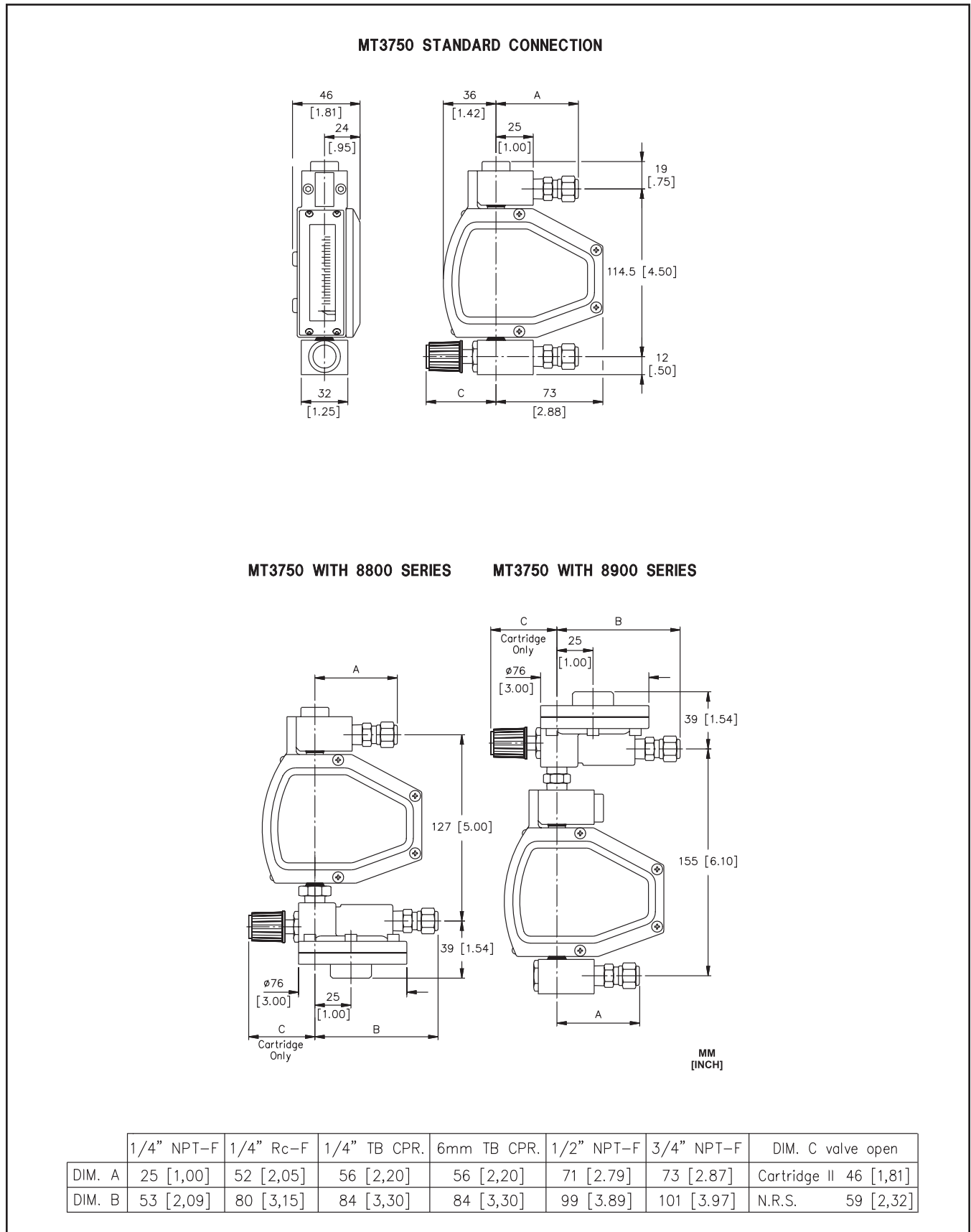

Figure 1-8 Dimensions for MT3750C Threaded Connections with Transmitter or Inductive Alarm

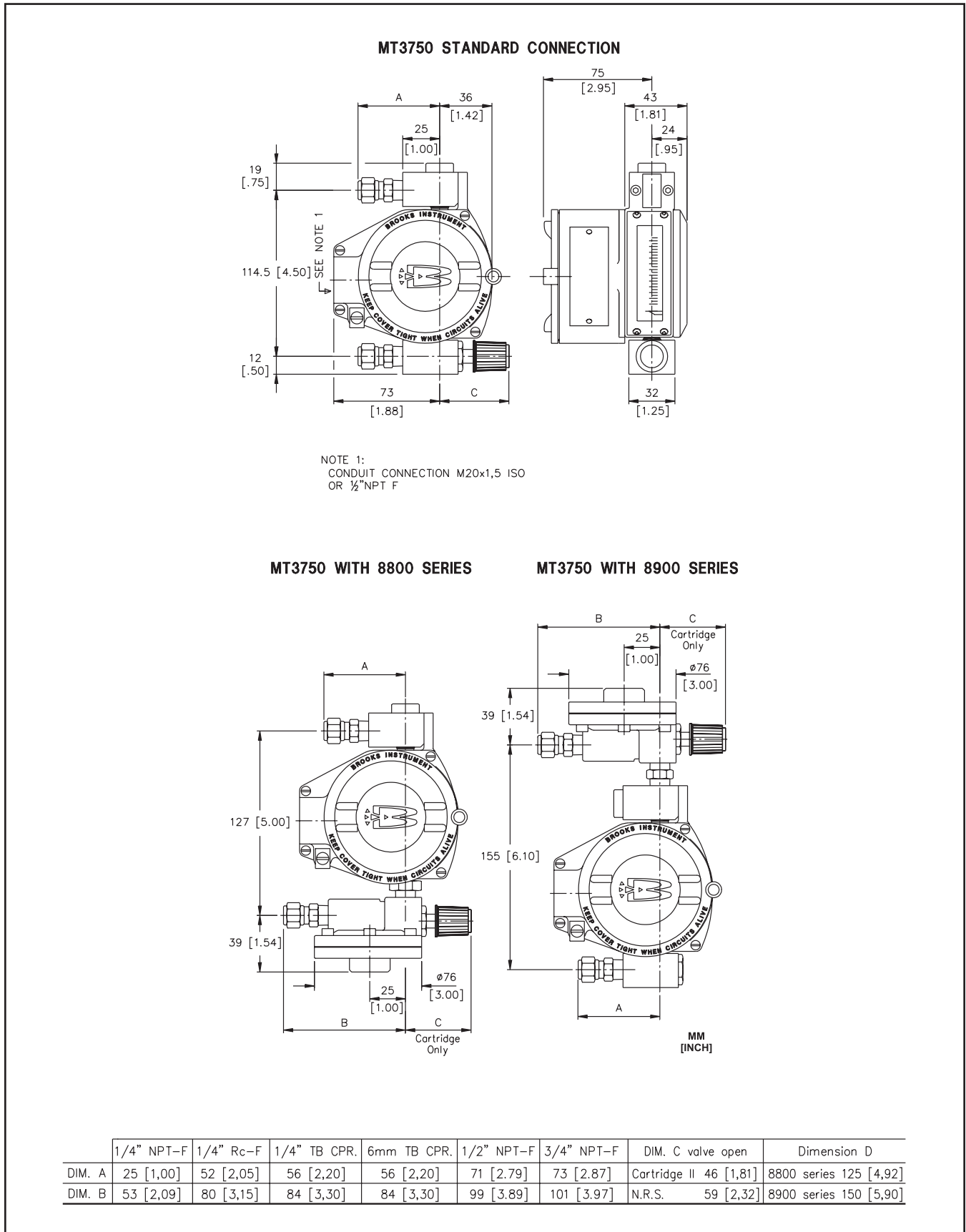

Figure 1-9 Dimensions for MT3750C Threaded Connections with Reed Switch Alarm

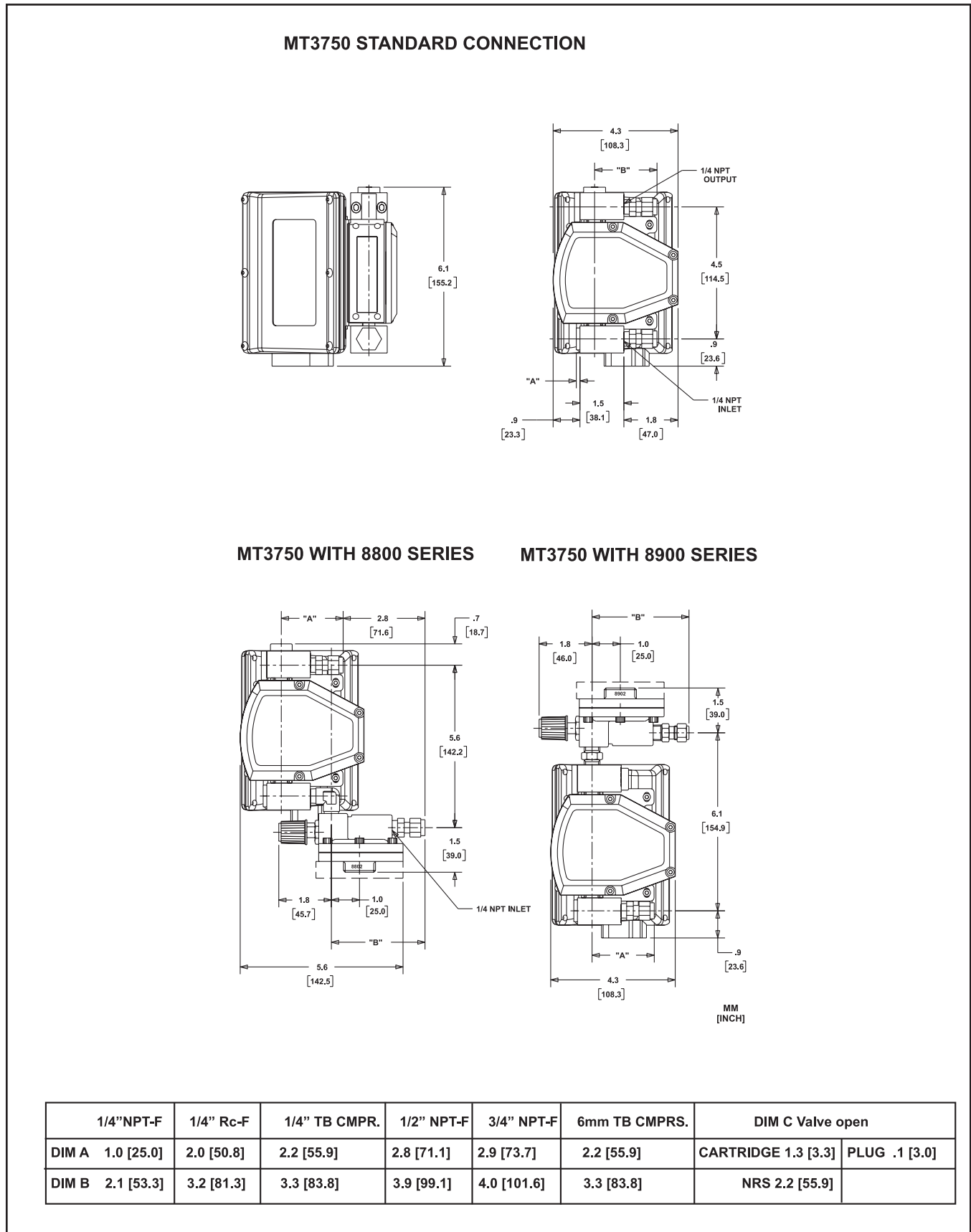
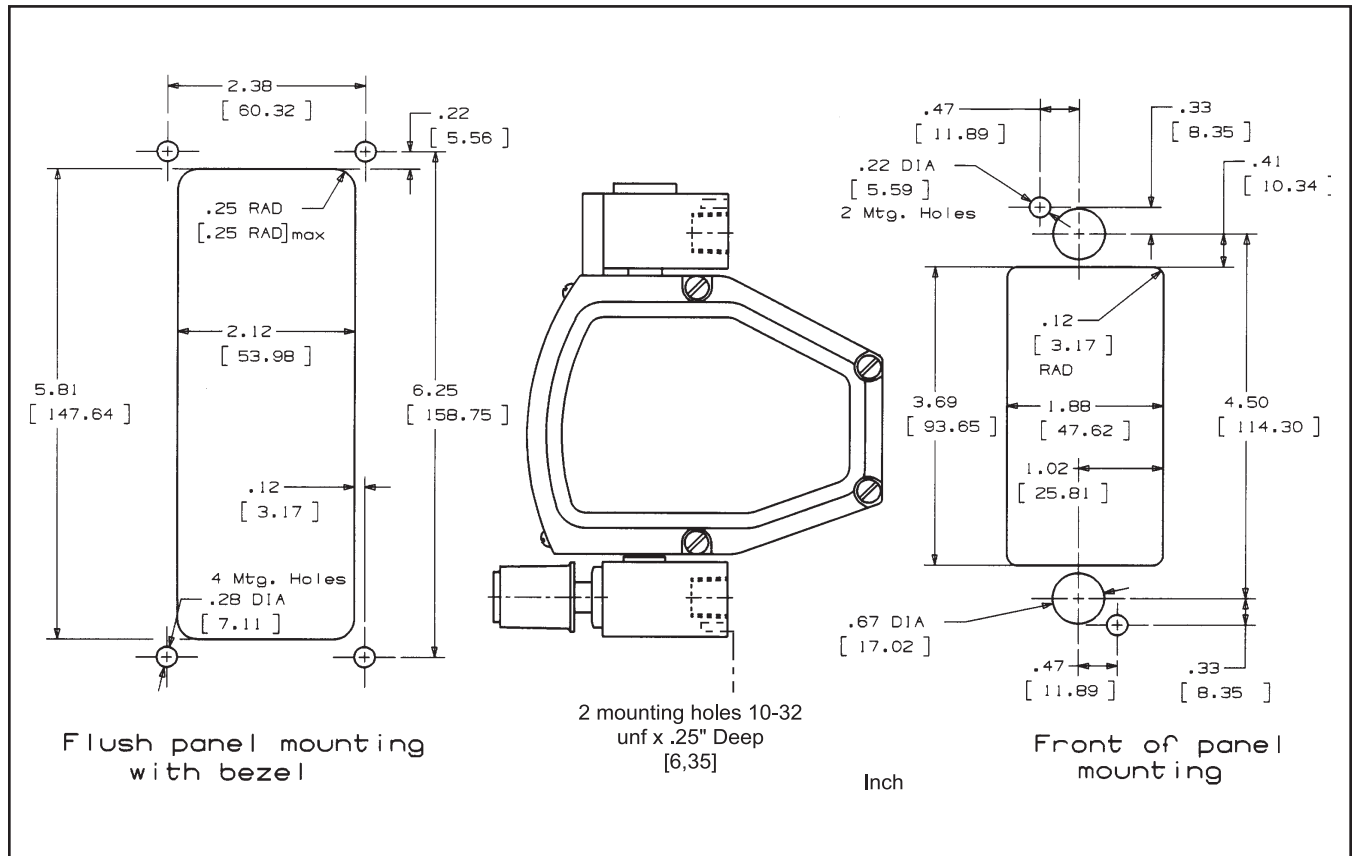

Figure 1-10 Dimensions for MT3750C Panel Mounting



## General

This section contains the procedures for the receipt and installation of the instrument. Do not attempt to start the system until the instrument has been permanently installed. It is extremely important that the start-up procedures be followed in the exact sequence presented.

## Receipt of Equipment

When the equipment is received, the outside packing case should be checked for damage incurred during shipment. If the packing case is damaged, the local carrier should be notified at once regarding their liability.

Remove the envelope containing the packing list. Carefully remove the instrument from the packing case. Make sure spare parts are not discarded with the packing materials. Inspect for damaged or missing parts.

If there is damage or missing parts, please visit [www.BrooksInstrument.com/Service](http://www.BrooksInstrument.com/Service) to submit a return.

## Recommended Storage Practice

If intermediate or long-term storage of equipment is required, it is recommended that the equipment be stored in accordance with the following:

- a. Within the original shipping container.
- b. Stored in a sheltered area, preferably a warm, dry, heated warehouse.
- c. Ambient temperature of 70° F (21° C) nominal, 109° F (43° C) maximum, 45° F (7° C) minimum.
- d. Relative humidity 45% nominal, 60% maximum, 25% minimum.

Upon removal from storage a visual inspection should be conducted to verify the condition of equipment is "as received".

## Return Shipment

Prior to returning any instrument to the factory for any reason, visit our website for instructions on how to obtain a Return Materials Authorization Number (RMA #) and complete a Decontamination Statement to accompany it: [BrooksInstrument.com/Service](http://BrooksInstrument.com/Service). All instruments returned to Brooks also require a Material Safety Data Sheet (MSDS) for the fluid(s) used in the instrument. Failure to provide this information will delay processing of the instrument.

Instrument must have been purged in accordance with the following:

### **WARNING**

**Before returning the device, purge thoroughly with a dry inert gas such as Nitrogen before disconnecting process connections. Failure to correctly purge the instrument could result in fire, explosion or death. Corrosion or contamination may occur upon exposure to air.**



### Transit Precautions

To safeguard against damage during transit, transport the instrument to the installation site in the same container used for transportation from the factory if circumstances permit.

### Removal From Storage

Upon removal of the instrument from storage, a visual inspection should be conducted to verify its "as-received" condition. If the instrument has been subject to storage conditions in excess of those recommended (See Section 2-3), it should be subjected to a pneumatic pressure test in accordance with applicable vessel codes.

### Installation of Flowmeter

#### **⚠ WARNING**

**If the inlet and outlet valves adjacent to the indicator are to be closed for any reason, the indicator must be completely drained. Failure to do so may result in thermal expansion of the liquid which can rupture the meter and cause possible personal injury.**

Recommended installation for Model MT3750C is as follows:

- A. Carefully remove the covers from each end of the flowmeter.
- B. Install the flowmeter with the inlet at the bottom and the outlet at the top.
- C. When installing the flowmeter in the process line, follow accepted plumbing practices for flanged or threaded fittings.
- D. Install the flowmeter within 5° of true vertical. Use of a level is recommended to determine the proper alignment.
- E. Installation of a bypass piping arrangement is recommended, Refer to Figure 2-1. Bypass piping permits the meter to be isolated from the flow line for servicing and cleaning.

#### **GENERAL NOTE FOR ELECTRONICS:**

The Electrical connections shall be made in such a way that the degree of ingress protection is maintained and is suitable for the installed environment. See UL 50, NEMA 250 and EN 60529. Most installations will require Type 4X or IP54 as a minimum installation.

### Installation of Inductive Alarm

#### **⚠ WARNING**

**Proper grounding of the instrument is required to avoid shock or personal injury. A terminal for grounding is provided inside the instrument identified with the symbol**



Figure 2-1 Typical Installation

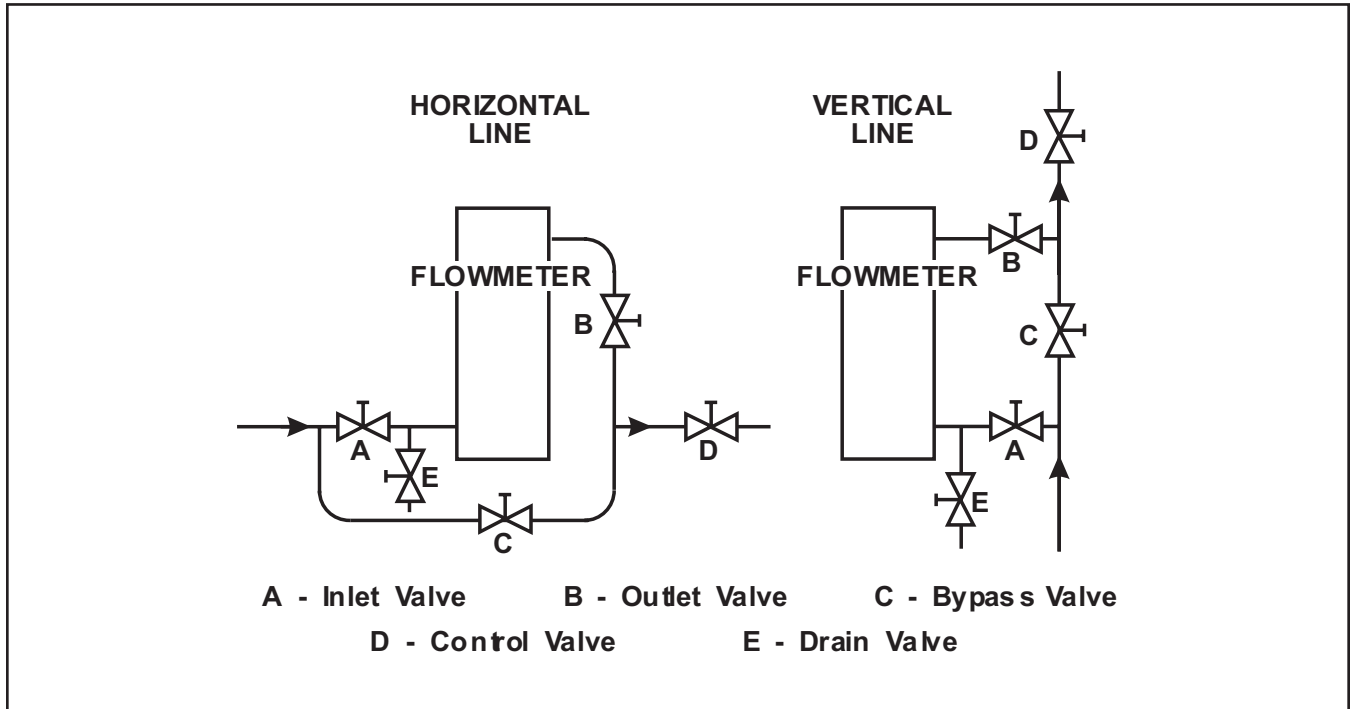

- A. For intrinsically safe operation (recognized by a BLUE COVER), intrinsic safety barrier selection, cable parameters and power supply limits must be in accordance with the entity parameters shown on drawing.
- B. If the area classification is a Division 2 or Zone 2, a barrier is not required. Note however when intrinsic safe apparatus is used without barrier, this apparatus may **NOT** be considered as intrinsically safe. This is because input protection diodes may be damaged without affecting normal operation. It is the customers' responsibility to clearly mark the apparatus when intrinsic safety is no longer valid.
- C. Connect the IS Alarm as shown in Figures 2-2 and 2-3.

Figure 2-2 Inductive Switch Wiring Diagram

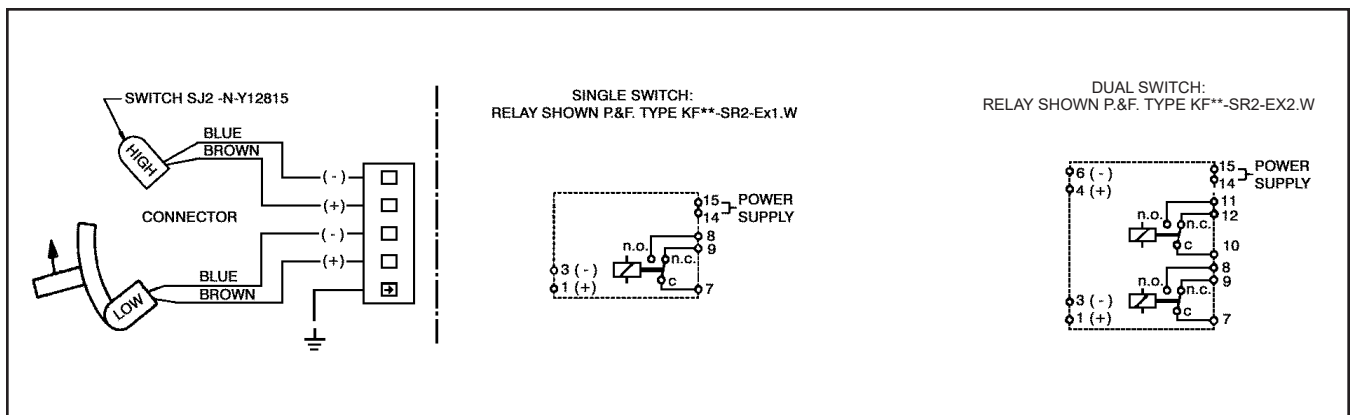
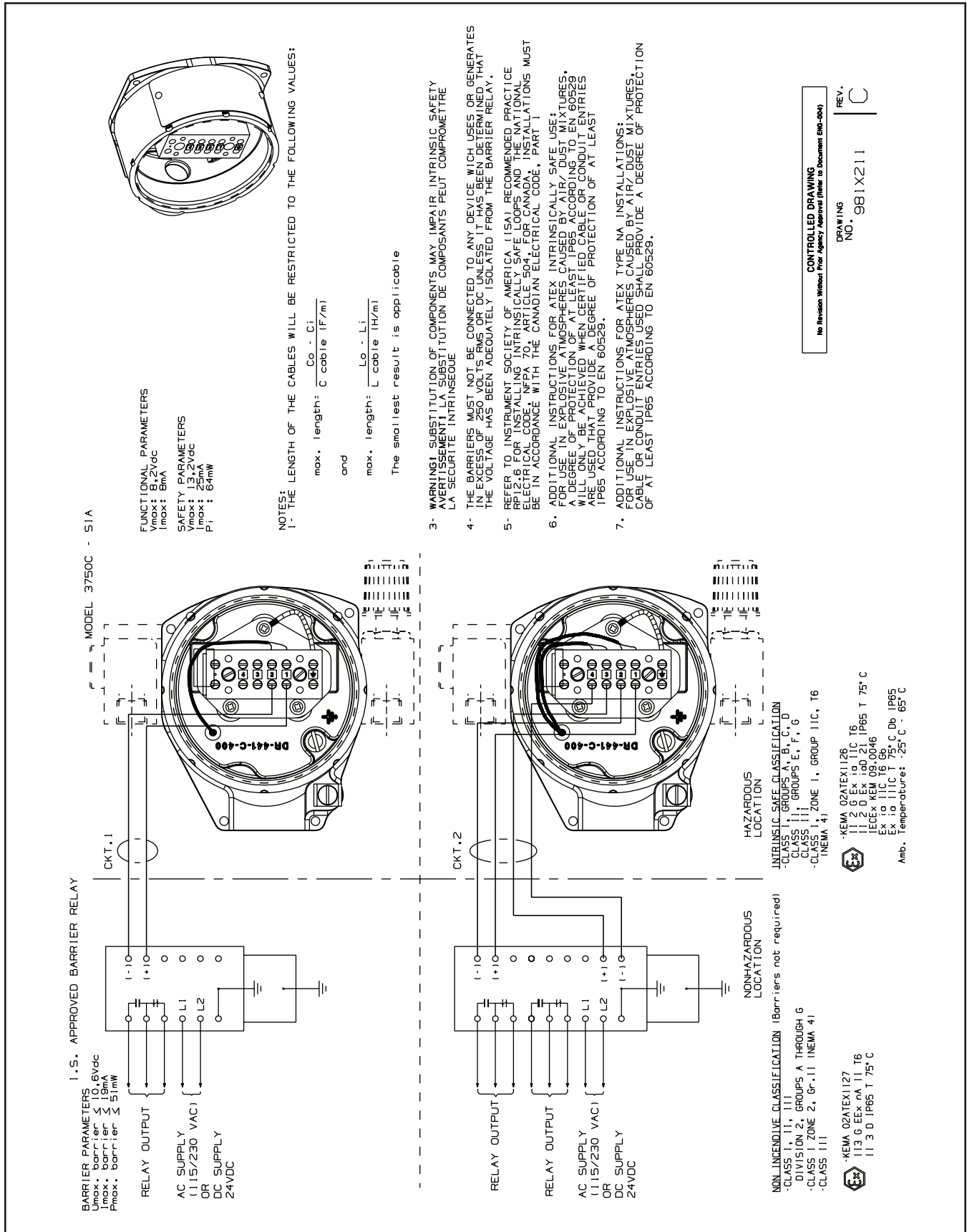



Figure 2-3 Inductive Switch Wiring



## Installation of Reed Switch Alarm

**⚠ WARNING**

Proper grounding of the instrument is required to avoid shock or personal injury. A terminal for grounding is provided inside the instrument identified with the symbol  .

**⚠ NOTICE**

**Class III Equipment:** The dc main input shall be supplied from a SELV (Separated Extra-Low Voltage) source.

A. Install meter as described in Section 2-7

**⚠ WARNING**

**High voltages may be present within the intergral alarm housing. Make no adjustments to the system while power is applied. Failure to heed warning can result in serious personal injury.**

B. For Factory Mutual Approved installations and for CSA/NRTL/C Certified installations, refer to Figures 2-4 and 2-5. On the system printed circuit board is a three terminal block marked "Alarm Circuit". The middle terminal is marked "Alarm In". This terminal is common for both high alarm and low alarm applications. A circuit is completed by connecting wires to "Alarm In" and to either "HI" for high flow alarm or "LO" for low flow alarm. Wires used should be in the range from 12 to 20 AWG. Remove 0.3 inches of insulation before inserting the wire into the terminal block and tightening the screw.

Figure 2-4 Reed Switch Alarm Installation Using IS Barriers.

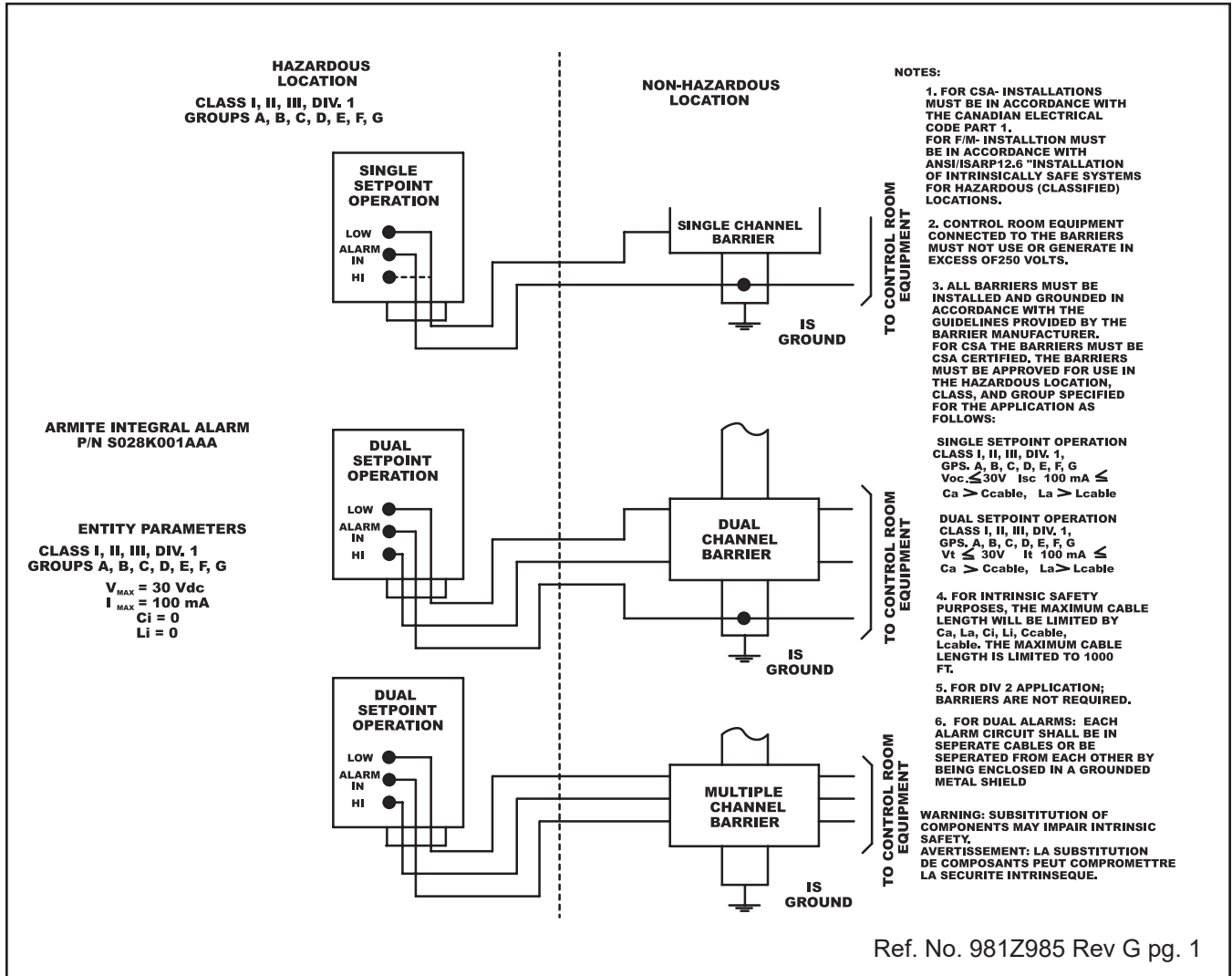

Figure 2-5 Reed Switch Alarm Installation Using P&F Relay Unit.

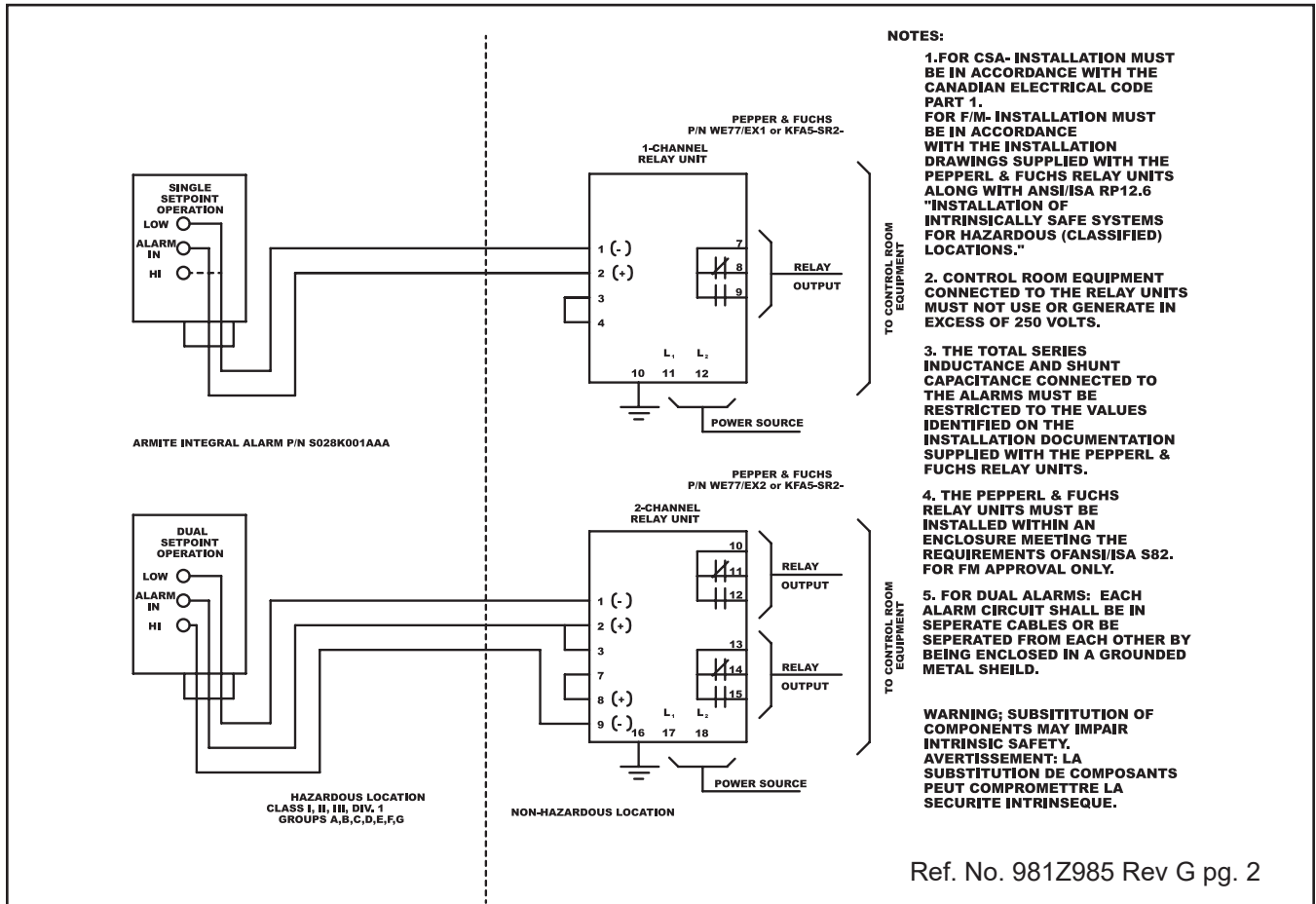
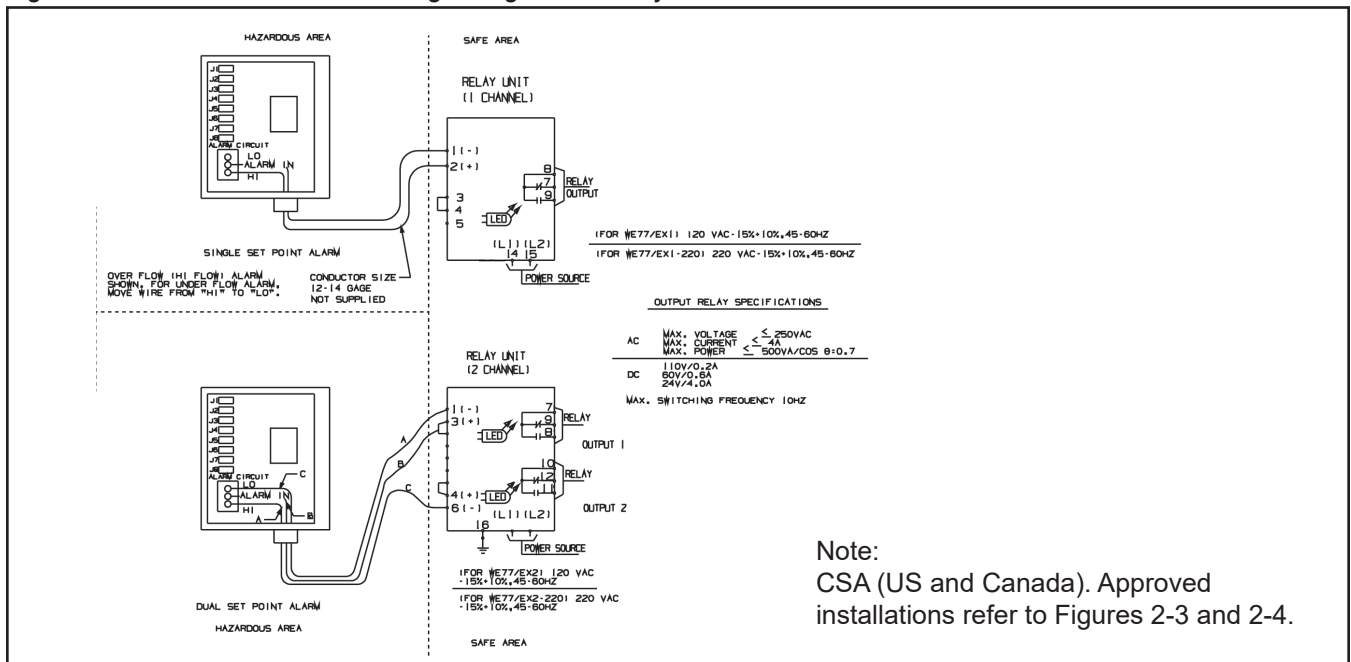

Figure 2-6 Reed Switch Alarm Wiring Using P & F Relay Unit.



For electrical hook-up of units requiring intrinsically safe power connections, use Brooks optional power supply and relay connected as in Figure 2-6 for the integral alarm.

### Installation of Transmitter

#### **WARNING**

**Proper grounding of the instrument is required to avoid shock or personal injury. A terminal for grounding is provided inside the instrument identified with the symbol**



#### **CAUTION**

**Since this is a magnetically activated device, strong magnetic fields and materials with magnetic properties may cause faulty operation when in close proximity to the flowmeter. This includes steel pipes, steel conduit, motors and transformers**

- A. For intrinsically safe operation (recognized by a BLUE COVER), intrinsic safety barrier selection, cable parameters and power supply limits must be in accordance with the entity parameters shown in Figure 2-6. Do not connect the zero wire (keep it floating) when the transmitter is in normal operation. The zero wire is not meant to be extended as zeroing must be done locally.
- B. If the area classification is Division 2 and Zone 2, a barrier is not required and cable parameters are not applicable. The electrical code will require the use of conduit for wire protection. Refer to Figure 2-7.
- C. If the installation is to be protected by Division 1 and Zone 1 explosion-proof methods, explosion-proof installation methods must be followed. Refer to Figure 2-8.
- D. The power supply voltage determines the maximum resistance of the loop, the associated cable and the barrier. Always be sure that the voltage on the transmitter is within the specifications.
- E. After installation and powering of the loop, the transmitter must be zeroed to compensate for any stray magnetic effects in the vicinity of the transmitter. The zero function may be activated as part of a periodical maintenance check. The zero function is activated by momentary (>2 seconds) shorting the zero wire to the ground wire while power is on. Connect the transmitter as shown in Figure 2-9.

Figure 2-7 Transmitter Wiring Diagram for I.S. Systems

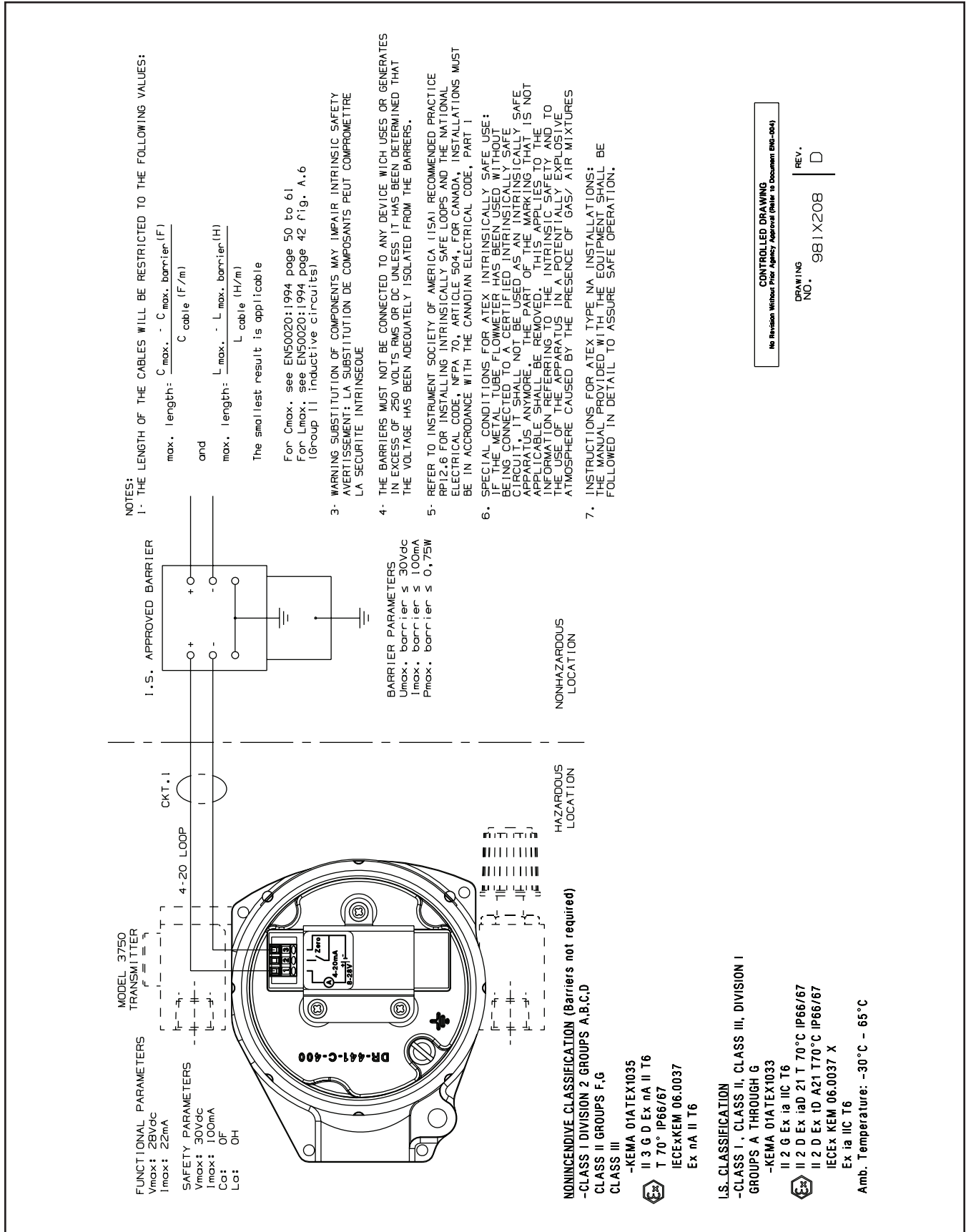



Figure 2-8 Transmitter Wiring Diagram for XP Systems

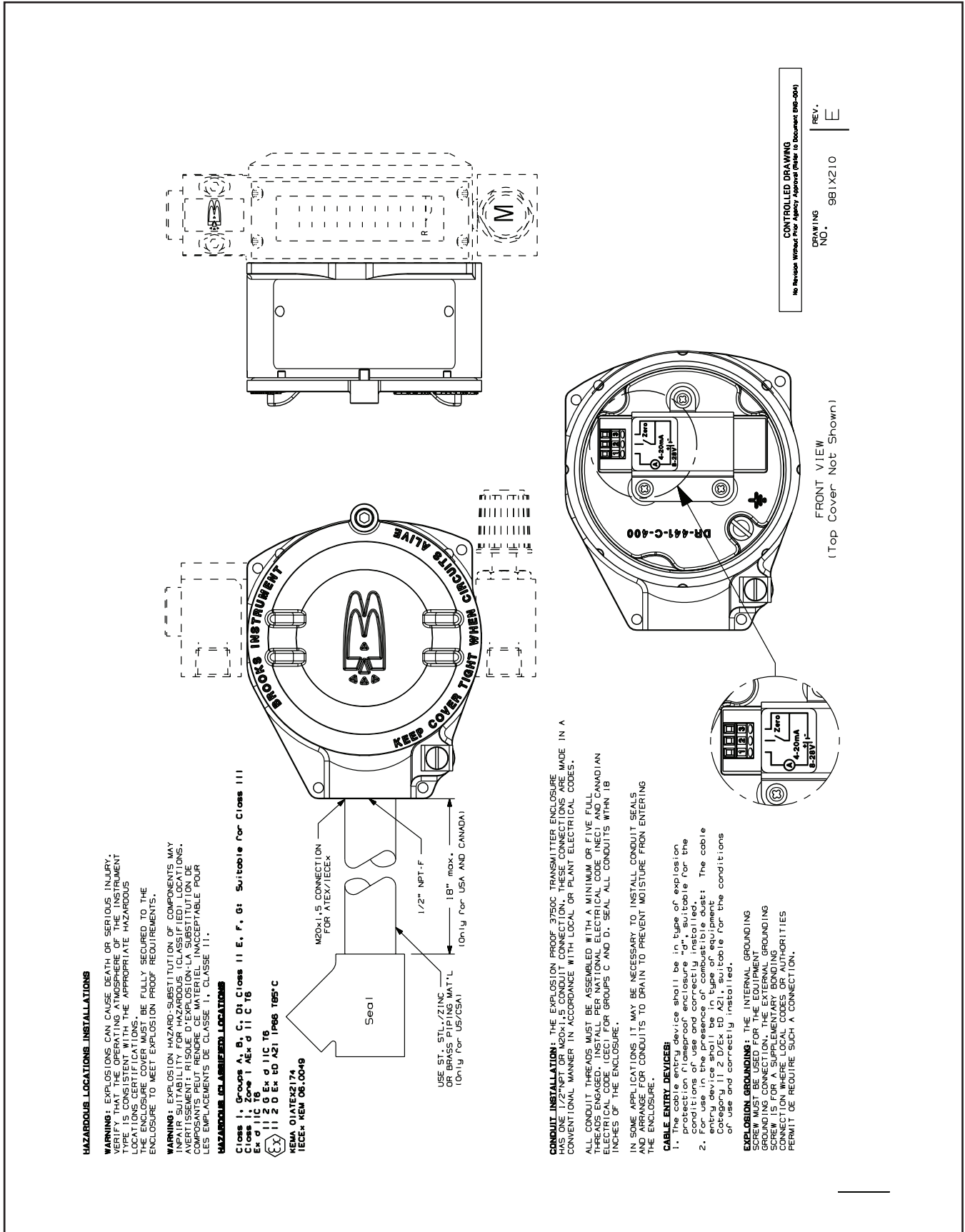
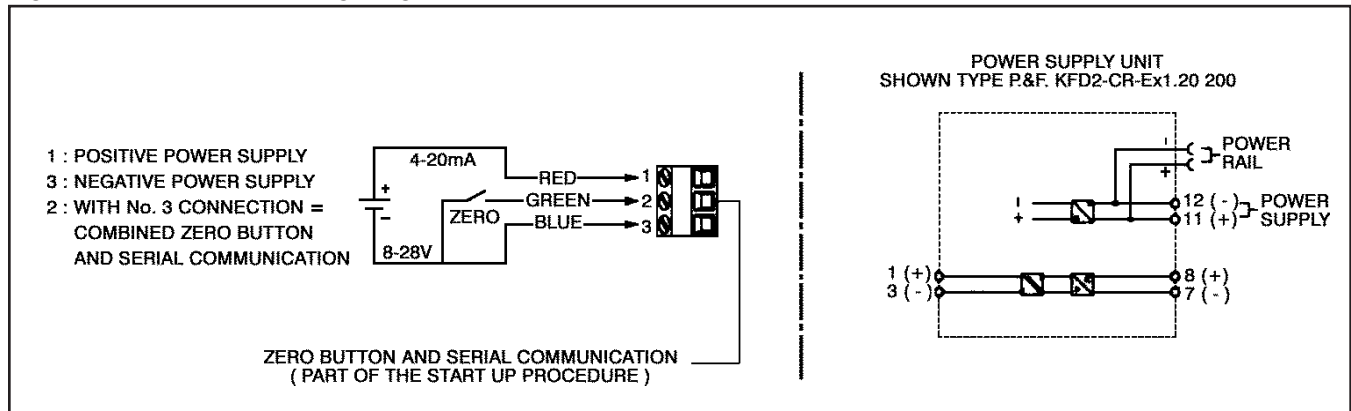

Figure 2-9 Transmitter Wiring Diagram



**⚠ NOTICE**

The Brooks (electric/electronic) equipment bearing the CE mark has been successfully tested to the regulations of the Electro Magnetic Compatibility (EMC directive 2004/108/EC). Special attention is required when selecting the signal cable to be used with CE marked equipment.

Brooks supplies high quality cables which meet the specifications for CE certification. If you provide your own signal cable you should use a cable which is completely screened with a 100% shield. D-Connectors should also be shielded using a metal cable screen clamping. The cable screen should be connected to the metal shell or gland and shielded at both ends over 360 degrees. The shield should be terminated to an earth ground.

See Essential Instructions for additional CE information.

## Operating Procedure

After the flowmeter has been properly installed in the process, it is ready for operation. When initiating flow, slowly open the valve to avoid a flow surge. Bypass is a help in bringing the flow on smoothly. Avoid starting a pump to supply the flowmeter without the use of a valve upstream of the flowmeter.

### **⚠ WARNING**

**Before operating the flowmeter, ensure all fluid connections have been properly tightened and, where applicable, all electrical connections have been properly terminated.**

### **⚠ CAUTION**

**Any sudden change in system pressure may cause mechanical damage to elastomer materials. Damage can occur when there is a rapid expansion of fluid that has permeated elastomer materials. The user must take the necessary precautions to avoid such conditions.**

## Operation of Inductive Alarm

- A. Start-up the meter as described in Section 3-1
- B. To modify the alarm set points, remove the side cover of the indicator housing by removing the four screws.
- C. Set the alarm position by loosening the screw mounting the switch to the plate.
- D. Hold the pointer to the desired alarm flow rate.
- E. Move switch assembly until the metal initiator, attached to the pointer, is not inserted into the switch.
- F. Tighten the screw mounting the switch to the plate.
- G. Replace the indicator housing cover and gasket and secure with the four screws.

## Operation of Transmitter

- A. Start-up meter as described in Section 3-1.
- B. Programming is performed prior to shipment. The transmitter is preprogrammed prior to shipment for the following parameters based on the order information, meter configuration and application. If parameters are not specified in the customer purchase order, the defaults inherent to the electronics will be as shown in (parenthesis).

### **Pre-Programmed Parameters**

Serial Number  
 Flow Rate units of measure (gpm)  
 Low Flow cutoff (5% FS flow)  
 Analog Output LoRange  
 (4 mA @ 0% flow)  
 Analog Output HiRange  
 (20 mA @ 100% flow)

## Operation of Reed Switch Alarm

**⚠ WARNING**

**High voltages may be present within the intergral alarm housing. Make no adjustments to the system while power is applied. Failure to heed warning can result in serious personal injury.**

- A. Start-up meter as described in Section 3-1
- B. Note: The alarm flow ranges specified in Table 3-1 are for reference only. Normal variations in sensors and meter scales may cause these values to shift. If the desired performance is not achieved, adjust alarm for the next nearest flow range and repeat the operation procedure. Setting the flow rate at which the alarm activates requires placing three jumpers on the system circuit board and positioning the two sensors. These combinations are listed in Table 3-1 and in the same table inside the alarm enclosure. The letters "A" and "B" in the table refer to a scale imprinted on the sensor bracket. To accurately set the alarm, it is necessary to establish flow through the meter at a rate corresponding to the desired set-point.

As an example, set the alarm for switch closure at flow rates below 50% of rated maximum flow. Disconnect any wires which are connected to the "Alarm Circuit" terminal strip. Connect an ohmmeter or continuity tester across the printed circuit board terminals marked "Alarm In" and "LO". Find, in the table, the row marked "Low Flow 40 - 70%". Follow the row across to the column marked "Jumpers". In this case, the jumpers required are J1, J4, and J6. Simply pull the jumpers out from their current positions and place them in the correct three places. Apply flow to the flow meter and adjust for 50% of rated maximum flow. Loosen the adjustment screw on the lower sensor holder and move the sensor until it reaches the lowest position possible on the sensor bracket. On the sensor holders is a white index line. Loosen the adjustment screw on the upper sensor holder and move the sensor until the index line is within the region marked "A". Watching the ohmmeter, slowly move the upper sensor within this region until a change in continuity takes place (switch closes or opens). Tighten the adjustment screw.

Fine adjustment of the set point may be required. Adjust the flow rate and observe the behavior of the system. Adjust the upper sensor up or down slightly as required to meet your requirements for accuracy. **After establishing setpoint, operate system over entire flow range to verify desired alarm performance.**

The position of the sensors along the flow tube is the only required sensor adjustment. **Adjustment of the distance between the sensor and the wall of the flow tube is made at the factory. This setting should not be altered.**

- C. Two jumper configurations allow simultaneous use of both the high

and low alarm circuits. In the first of these configurations, an alarm is always active. If the flow rate is under the set point, the low alarm circuit is closed. If the flow exceeds the set point, the low alarm circuit opens and the hi alarm circuit closes. There is hysteresis associated with reed switches, so the flow rates at which the alarm switches between HI and LO will be slightly different depending on whether the flow rate is increasing or decreasing.

The second “Dual” alarm option allows separately adjusting the set points for low flow alarm and high flow alarm within a limited range of the maximum flow rate of the meter.

The dual setpoint alarm is set in the same manner as described in Section 3-4. Simply use two ohmmeters to observe the behavior of both circuits.

Table 3-1 Interior Label MT 3750 Ar-Mite Alarm.

**Alarm Programming Table<sup>1</sup>**

Alarm Flow Range	Jumper Positions	Adjust Upper Sensor in Region <sup>2</sup>	Lower Sensor Position
High, 60-100%	J-2,5,7	B	Bottom of Slot
High, 40-75%	J-1,4,6	A	Bottom of Slot
High, 0-40%	J-1,3,5	B	Bottom of Slot
Low, 55-100%	J-2,3,7	B	Bottom of Slot
Low, 40-75%	J-1,4,6	A	Bottom of Slot
Low, 0-40%	J-1,5,7	B	Bottom of Slot
Dual: High, 40-75% Low, 30-60%	J-1,4,6	A	Bottom of Slot
Dual: High, 40-75% Low, 10-45%	J-1,6,8	A (High Set)	Region B (Low Set)

<sup>1</sup> These ranges for reference only.

<sup>2</sup> Final Sensor position may be slightly outside of these ranges.

Figure 3-1 Reed Switch Alarm.

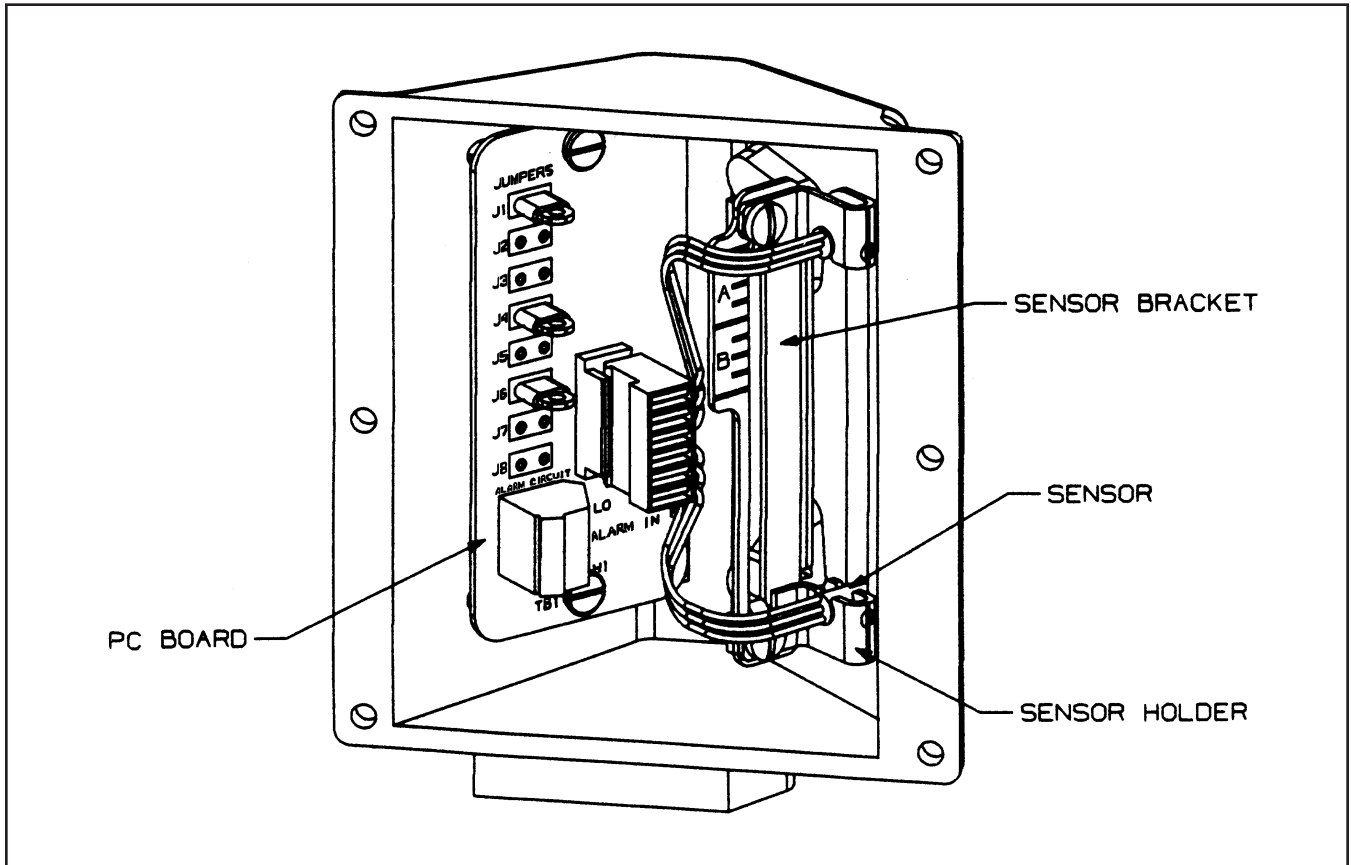

## General

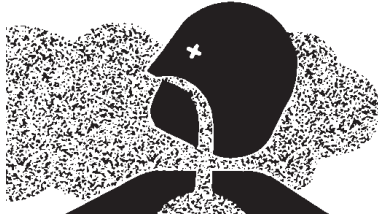
	<b>⚠ WARNING</b>
<b>METER/CONTROLLER SEAL COMPATIBILITY</b>	
<p>Products in this manual may contain metal or elastomeric seals, gaskets, O-rings or valve seats. It is the "user's" responsibility to select materials that are compatible with their process and process conditions. Using materials that are not compatible with the process or process conditions could result in the Meter or Controller leaking process fluid outside the pressure boundary of the device, resulting in personnel injury or death.</p> <p>It is recommended that the user check the Meter or Controller on a regular schedule to ensure that it is leak free as both metal and elastomeric seals, gaskets, O-rings and valve seats may change with age, exposure to process fluid, temperature, and /or pressure.</p>	

<b>⚠ WARNING</b>
If it becomes necessary to remove the instrument from the system, power to the device must be disconnected.

<b>⚠ WARNING</b>
If it becomes necessary to remove the flowmeter from the system after exposure to toxic, pyrophoric, flammable or corrosive gas, purge the flowmeter thoroughly with a dry inert gas such as Nitrogen before disconnecting the gas connections. Failure to correctly purge the flowmeter could result in fire, explosion or death. Corrosion or contamination of the flowmeter upon exposure to air, may also occur.

<b>⚠ CAUTION</b>
It is important that this device only be serviced by properly trained and qualified personnel.

**Service Information****⚠ WARNING**

**Should the equipment require repair, contact the nearest Brooks Sales/Service office. It is important that servicing is performed only by trained and qualified service personnel. If equipment is not properly serviced, serious personal injury and/or damage to the equipment could result.**

**On Site Adjustment/Calibration**

The transmitter can be adjusted and/or calibrated with the help of a Windows 95/98 calibration program in combination with an applicable interface that can be plugged into any RS232 serial PC-port. The calibration data is stored in the non-volatile memory in the transmitter. After calibration the transmitter functions as a stand alone device (consult factory for more details).

PC interface is needed to calibrate the transmitter. With this interface the transmitter can be connected to the serial RS232 port of a computer. At power/start-up the transmitter is waiting (~2 seconds) for serial communication before entering normal operation. When a serial communication is established, the transmitter is instructed to sustain its low-power mode (typically 2.6 mA). In this low-power mode the transmitter is directly powered from the RS232 port without the need of an external power supply.

Software Kit (Calibration CD-ROM and RS232 Interface): part number: F535Y001ZZZ



**General**

When ordering parts, please specify:

Brooks Serial Number  
Model Number  
Part Description  
Quantity

(Refer to Figure 5-1, and Tables 5-1, 5-2).

Figure 5-1 Model MT3750 Exploded View

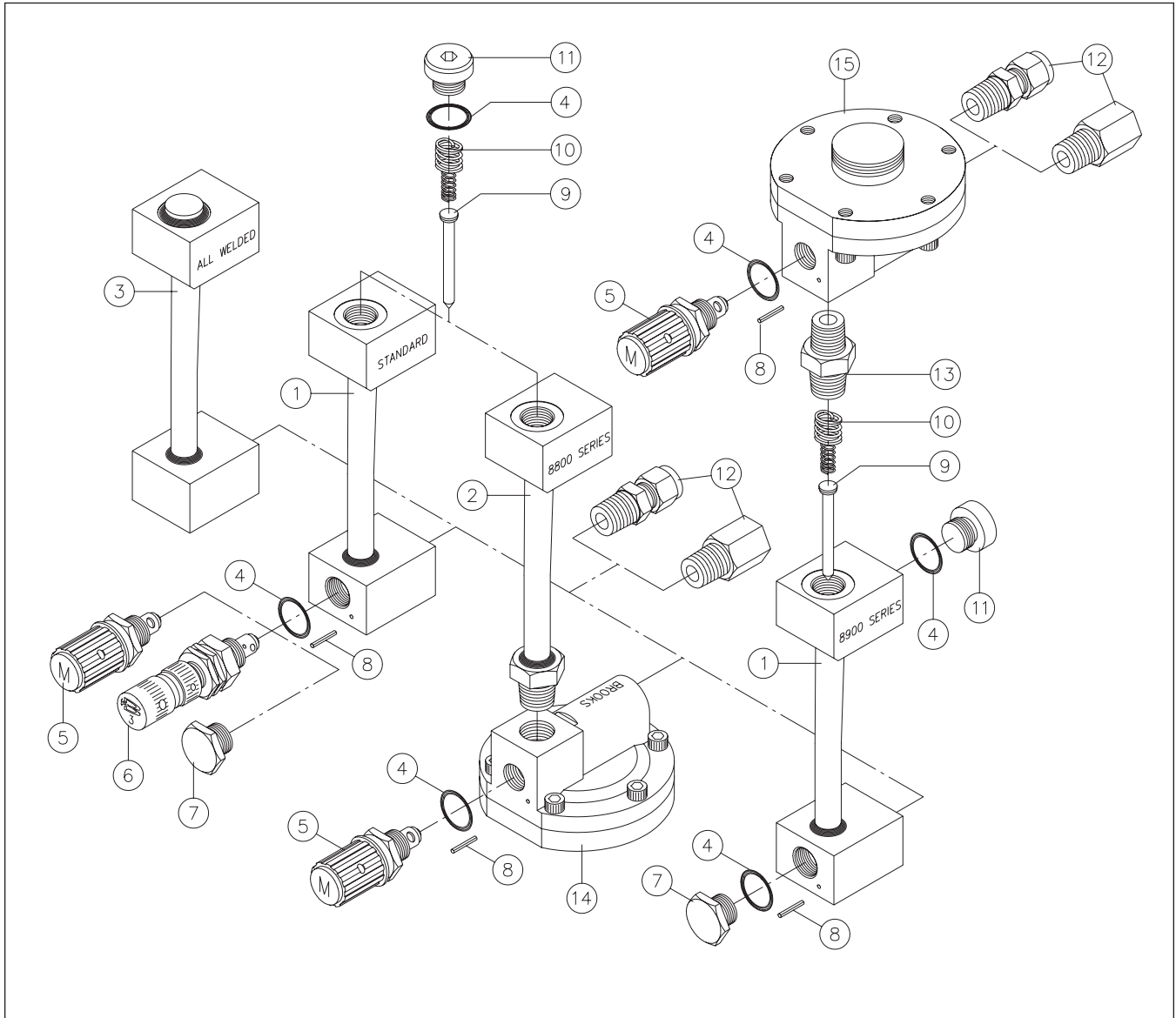

## LIMITED WARRANTY

Visit [www.BrooksInstrument.com](http://www.BrooksInstrument.com) for the terms and conditions of our limited warranty.

## BROOKS SERVICE AND SUPPORT

Brooks is committed to assuring all of our customers receive the ideal flow solution for their application, along with outstanding service and support to back it up. We operate first class repair facilities located around the world to provide rapid response and support. Each location utilizes primary standard calibration equipment to ensure accuracy and reliability for repairs and recalibration and is certified by our local Weights and Measures Authorities and traceable to the relevant International Standards.

Visit [www.BrooksInstrument.com](http://www.BrooksInstrument.com) to locate the service location nearest to you.

## START-UP SERVICE AND IN-SITU CALIBRATION

Brooks Instrument can provide start-up service prior to operation when required.

For some process applications, where ISO-9001 Quality Certification is important, it is mandatory to verify and/or (re)calibrate the products periodically. In many cases this service can be provided under in-situ conditions, and the results will be traceable to the relevant international quality standards.

## SEMINARS AND TRAINING

Brooks Instrument can provide seminars and dedicated training to engineers, end users and maintenance persons.

*Please contact your nearest sales representative for more details.*

Due to Brooks Instrument's commitment to continuous improvement of our products, all specifications are subject to change without notice.

## TRADEMARKS

Brooks, Ar-Mite and NRS are trademarks of Brooks Instrument, LLC  
All other trademarks are the property of their respective owners.



Installation-Manual-MT3750C-EN/541B063AAG-B/2023-4

### Global Headquarters

#### Brooks Instrument

407 West Vine Street

Hatfield, PA

19440-0903 USA

Toll-Free (USA): 888-554-FLOW

T: 215-362-3500

[BrooksAM@BrooksInstrument.com](mailto:BrooksAM@BrooksInstrument.com)

A list of all Brooks Instrument locations and contact details can be found at [www.BrooksInstrument.com](http://www.BrooksInstrument.com)

© Copyright 2023 Brooks Instrument, LLC All rights reserved. Printed in U.S.A.

**BROOKS**<sup>®</sup>  
INSTRUMENT  
*Beyond Measure*