

This Quick Start Guide applies to the following Brooks products(s):
 • E-Series: 5850EMH, 5851EMH
 In an effort to be more eco-friendly, Brooks is no longer supplying printed instruction manuals with the product shipments to reduce our paper consumption.
 For your product's complete instruction manual, please download it at brooksinstrument.com/documentation

Dear Customer,
 Thank you for your purchase. We appreciate this opportunity to service your flow measurement and control needs with a Brooks Instrument device. Brooks' award-winning meters and controllers consistently rank at the top of their category for accuracy, reliability and user preference, as judged by the audience that matters - real users of flow instrumentation, like you.
 But Brooks' products are only half of the story. You are backed by Brooks' unsurpassed local technical expertise in virtually every corner of the planet. Your local Brooks product and application specialist is truly your "partner in flow". They have been extensively trained to help you select the optimal solutions for your flow measurement or control needs and offer years of experience solving application problems just like yours.
 Should you require any additional information concerning Brooks' products and services, please contact your local Brooks Sales and Service office listed on the back cover of this guide.
 Sincerely,
 Brooks Instrument

Global Headquarters
Brooks Instrument
 407 West Vine Street
 Hatfield, PA 19440-0903 USA
 Toll-Free (USA): 888-554-FLOW
 Tel (215) 362 3700
 Fax (215) 362 3745
BrooksAm@BrooksInstrument.com

A list of all Brooks Instrument locations and contact details can be found at www.BrooksInstrument.com

Brooks is a trademark of Brooks Instrument, LLC.
 All other marks are property of their respective owners.
 PN: 541B209AAG/B
 Reference: 834z986



© Copyright 2017, Brooks Instrument, LLC.
 All rights reserved. Printed in USA.

CAUTION

- Incorrect voltage will cause flowmeter damage or failure.
- If your mass flow product operates with current I/O it sources its own 4-20mA output signal. Do not source this output with an external supply.
- Do not use a current sinking PLC output card.
- If your mass flow product operates with current I/O it is an input sinking device.

WARNING

- Read all instructions prior to installing, operating and servicing this product. Follow all warnings, cautions and instructions marked on and supplied with this product.
- Install your equipment as specified in the installation instructions in the appropriate instruction manual and per local and national codes. Connect all products to the proper electrical and pressure sources.
- Ensure that all equipment doors are closed and protective covers are in place, except when maintenance is being performed by qualified persons, to prevent electrical shock and personal injury.
- Do not operate this instrument in excess of the specifications marked on and supplied with this product. Failure to heed this warning can result in serious personal injury and/or damage to the equipment.
- Before operating the device, ensure all electrical connections have been properly terminated.
- If it becomes necessary to remove the device from the system, power to the device must be disconnected.
- If it becomes necessary to remove the device from the system after exposure to toxic, pyrophoric, flammable or corrosive gas, purge the device thoroughly with a dry inert gas such as nitrogen before disconnecting the gas connections. Failure to correctly purge the device could result in fire, explosion or death.
- Corrosion or contamination of the device upon exposure to air may also occur.

X-TMF-585xEMH-QS-eng
 PN: 541B209AAG/B
 June, 2017

Quick Start Guide

585xEMH High Temperature Mass Flow Controllers

Thermal Mass Flow



Step 1: Location/Orientation

The instrument may be located anywhere in the process line, as long as the following conditions are met:

- Ambient temperature must remain between 85° and 105°C (185°F and 221°F).
- The instrument (cable connections, wiring compartments and/or conduit openings) should be accessible for service.

The instrument can be mounted in any orientation. It's best if the mounting orientation matches the orientation specified on the Calibration Data Sheet. Refer to Figure 1 for the different mounting options:

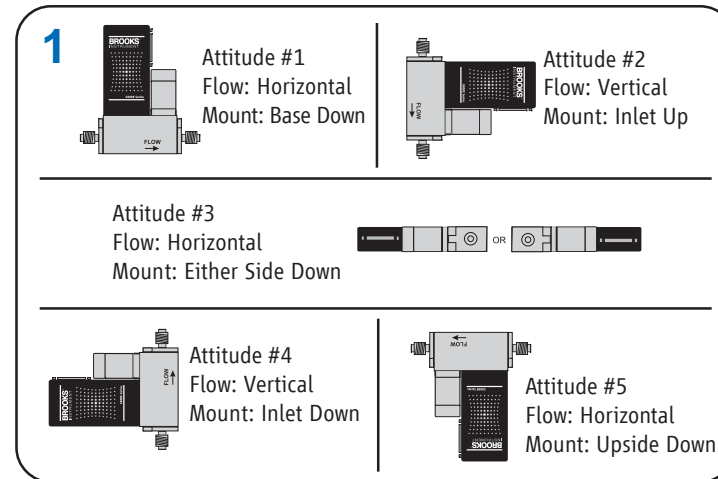

Step 2: Mounting the Controller to a Plate, Shelf or Panel

2
5850EMH

5851EMH
8-32 UNC-2B 0.25 [6.4] DEEP (2X)

Inch
 [mm]

Step 3: Gas Connections

3

WARNING

Any rotation of the inlet or outlet fitting during installation of a metal seal device may result in a leak. Always use two wrenches when attaching process line to prevent rotation.

After mounting the Controller, carefully connect and tighten the process lines. Ensure the fittings are leak-free.

Step 4: Remote Electronics Box

The remote electronics box can be mounted in any position that is convenient and within reach of the high temperature cable. The temperature limit of the electronics is 0-50°C (32°F -122°F).

Connect the remote electronics box with the controller utilizing the 15-pin D sub connector on the end of the cable which is wired to the remote electronics box.

4

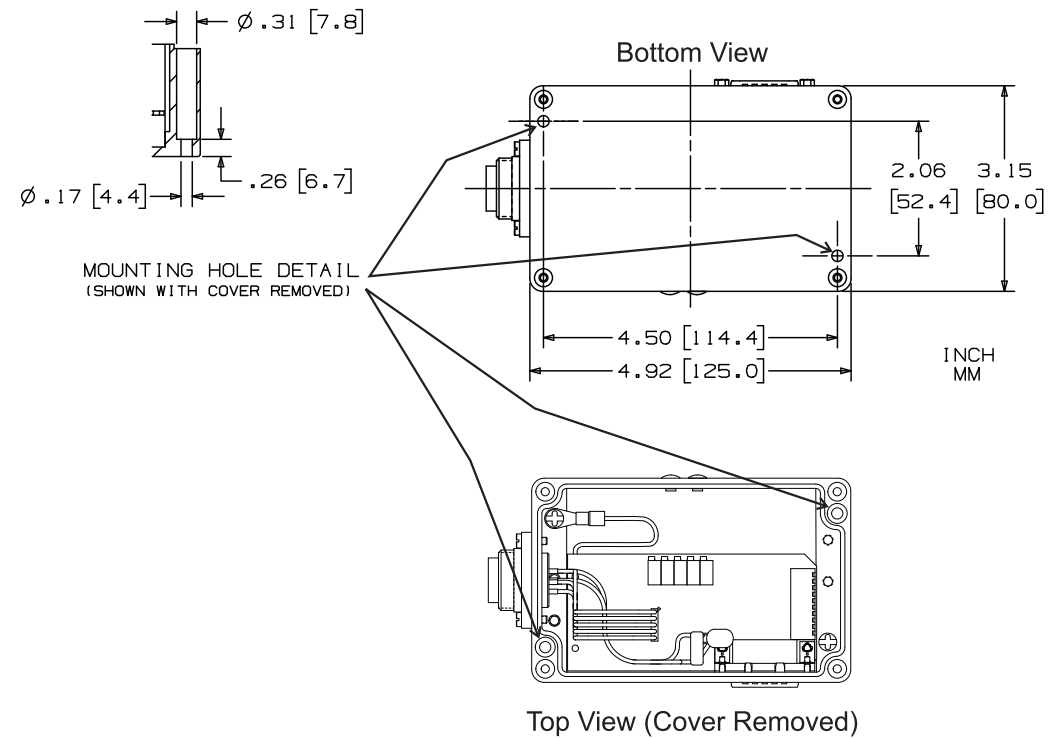

Step 5: Electrical Connections

5

15 Pin D-Connector

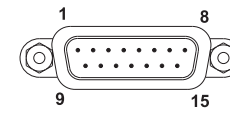

Pin	Function
1	Command Common
2	0-5 Volt, Signal Output
3	Not Used
4	Not Used
5	+15 Vdc Supply
6	-15 Vdc Supply
7	Valve Voltage Out
8	Command Input
9	Supply Voltage Common
10	0-5 Volt Signal Common
11	+5 Vdc Reference Output
12	Valve Override
13	Not Used
14	Chassis Ground
15	Not Used

To insure proper operation, the Model 585xEMH must be connected per Figure 5.

As a minimum, the following connections must be made:

Voltage I/O Version

- Chassis Ground (Pin 14)
- Signal Common (Pin 10)
- Signal Output (Pin 2)
- +15 Vdc Supply (Pin 5)
- -15 Vdc Supply (Pin 6)

Each device is factory adjusted to provide a flow signal of zero volts (± 10 mVdc) at zero flow. The adjustment is made in our calibration laboratory which is temperature controlled to the temperature specified at the time of order. After initial installation and warm-up in the gas system, the zero flow indication may be other than the factory setting. This is primarily caused by changes in temperature between our calibration laboratory and the final installation. The zero flow reading can also be affected, to a small degree, by changes in line pressure and mounting attitude.

To check zero, always mount the controller in its final configuration and apply power to the instrument and any associated heaters for 60 minutes to reach a stable thermal condition prior to applying flow. Flow the process fluid into the instrument and allow sufficient time for the sensor to reach normal operating temperature.

Note: Before zeroing the instrument, zero pressure differential MUST be established across the device. If there is pressure across the instrument during the zero process, any detected flow through the sensor will be misinterpreted as the zero flow reading. This will result in calibration inaccuracy during normal operation.

Close the shutoff valve downstream of this instrument to eliminate any pressure differential across the instrument. Once zero differential pressure is established and verified, check the flow output signal using a suitable voltmeter. If it differs from the factory setting, adjust it by removing the lower pot hole plug (refer to Figure 4) which is located closest to the 7-pin circular connector on the remote electronics module. Adjust the zero potentiometer until the desired output signal is within ± 10 mV of zero on the output of the device.

Step 6: Operation

After the flow controller has been installed in the system it is ready for operation.

Controller: You must provide a setpoint/command signal to the controller. The controller will read the setpoint signal and will automatically adjust the valve to the appropriate position to achieve the desired flow and will provide a flow signal proportional to the full scale flow of the device as indicated on the device label.

Equipment Receipt and Return Procedures

Receipt of Equipment

When the equipment is received, the outside packing case should be checked for damage incurred during shipment. If the packing case is damaged, the local carrier should be notified at once regarding his liability. A report should be submitted to the nearest Brooks Instrument location listed on the Global Service Network page on our website: brooksinstrument.com/service-support

Remove the envelope containing the packing list. Carefully remove the instrument from the packing case. Make sure spare parts are not discarded with the packing materials. Inspect for damaged or missing parts.

Return Shipment

Prior to returning any instrument to the factory for any reason, visit our website for instructions on how to obtain a Return Materials Authorization Number (RMA #) and complete a Decontamination Statement to accompany it: brooksinstrument.com/service-support All instruments returned to Brooks also require a Material Safety Data Sheet (MSDS) for the fluid(s) used in the instrument. Failure to provide this information will delay processing of the instrument.

Instrument must have been purged in accordance with the following:

⚠ WARNING

Before returning the device, purge thoroughly with a dry inert gas such as Nitrogen before disconnecting process connections. Failure to correctly purge the instrument could result in fire, explosion or death. Corrosion or contamination may occur upon exposure to air.