

INSTALLATION & OPERATION INSTRUCTIONS OF GS-L GLASS TUBE FLOWMETER

Standard glass tube flowmeters are available in various air and water ranges and configurations. At your request, flow curves for other gases and liquids can be supplied, and direct read scales are available for such fluids on a special order basis.

UNPACKING

Precautions have been taken to prevent any damage from occurring during shipment. If the meter is received damaged, *report it to the carrier immediately*. Verify that you have the model and flow range that you require.

ACHIEVING ACCURATE FLOWRATES

The meter is calibrated at standard temperature and pressure (68° F/20° C and 14.696 PSIG/ 1 Bar Gauge) in vertical position. Using the meter under different conditions will yield inaccurate readings. To obtain an accurate flowrate, the float must be read at the position indicated on the meter. Additionally, the flowmeter should be installed in a manner that minimizes both external vibrations and internal flow variations. Special care should be taken so that the connections to the meter's inlet and outlet fittings do not overly restrict the liquid or gas flow being metered. This could result in a reduced flow volume, preventing the meter from reaching its maximum flowrate. Furthermore, internal pressures could be affected, which can cause inaccurate flow readings. Prior to use, any air/gas trapped in the meter should be slowly purged and the meter should be checked for leaks.

INSTALLATION

In order to mount the meter on a panel, two clearance holes must be drilled. (Refer to diagrams for the correct locations of the 1 1/32" diameter clearance holes.) The meter is secured to the panel using the provided panel nuts. The meter is supplied with 3/8-18 FNPT non-rotating fittings. When installing connections in the meter, place a 1" wrench on the hex to prevent the meter's fittings from rotating. (Use pipe thread sealant or Teflon® tape to achieve a positive seal.) **When installing the 3/8-18 MNPT fittings into the meter, torque to 60 in-lbs. maximum.** Failure to hold the fittings or over-torquing the fittings could cause serious damage to the meter.

CAUTION

When surface mounting on a panel, clearance must be allowed for The pressure relief holes at the back of the flowmeter. Failure to do so may result in injury in the event of an overpressure failure.

DISASSEMBLY

If the meter is to be disassembled for any reason, be sure to first shut off the process line pressure and bleed off any pressure in the meter. Remove the meter from the process line. Disassemble the unit as follows: On a non-valve unit, use a 1/4" Allen wrench to remove the plug from the front of the flowmeter. On a valve unit, remove the knob first, then using a 3/4" hex socket, remove the valve assembly. Slide the shield out of its track. On panel mount units, use a 1" wrench to remove the top and bottom fittings. On inline units, use a 1" wrench to remove mounting plugs from top and bottom end blocks. Tube, float and springs can now be removed.

CLEANING

Occasional cleaning may be required if dirt appears in the flow tube or if float movement becomes restricted. In order to clean the tube assembly or replace parts, the meter must be removed from the process line (see disassembly/reassembly instructions). The tube and float should be cleaned with a mild liquid detergent and a soft brush or swab.

RE-ASSEMBLY

Before proceeding, all pieces should be rinsed/flushed with clean water, and dried thoroughly with clean dry air or nitrogen. Mount the bottom end block in the "U" shaped housing. Either fitting can be used on non-valve units either fitting can be used. On valve units, use the fitting with the valve seat. On inline units either mounting plug can be used. Place the background label in the housing, then put the bottom spring into the tube (hat shaped spring). Slide the bottom of the tube over the seal on the bottom end block. Check the float orientation and slide it into the tube from the top, install the top spring. Place the top end block into the "U" shaped housing and slide the seal into the tube. While holding the top end block in position, install the remaining fitting or plug. Slide the clear front shield into its track. On non-valve units, use a 1/4" Allen wrench to replace the plug on the front of the unit. On valve units, use a 3/4" hex socket to replace the valve assembly. Place the knob on the valve stem and close the valve. Reinstall the meter in the process line. On valve units, slowly pressurize the meter. Check for leaks before resuming operations. If you have any questions regarding installation, maintenance or use of this flowmeter, please call the Customer Service Department.

SPECIFICATIONS	
ACCURACY:	± 5% Full Scale – 65 mm ± 3% Full Scale – 150 mm
REPEATABILITY:	±1%
FLOATS:	Black Glass or Stainless Steel
HOUSING:	Anodized Aluminum
WETTED COMPONENTS:	Stainless Steel with Viton® (Brass with Buna-N Optional)
FITTINGS:	3/8-18 FNPT Fittings
GLASS TUBE:	Precision Formed Borosilicate Glass
SCALE LENGTH:	65 MM or 150 MM
MAXIMUM TEMPERATURE:	250°F (121 °C)
MAXIMUM PRESSURE:	250 PSI (17 Bar @ 100°F)

CAUTION

THIS FLOWMETER IS DESIGNED FOR USE WITH NON-HAZARDOUS FLUIDS AT PRESSURES UP TO 250 PSI @ 100°F (17 BAR @ 38°C) AND TEMPERATURES UP TO 250 °F (121 °C). DO NOT USE HAZARDOUS FLUIDS AND DO NOT EXCEED TEMPERATURE OR PRESSURE LIMITS. USE WITH HAZARDOUS FLUIDS OR EXCEEDING THE PRESSURE AND TEMPERATURE LIMITS MAY CAUSE FAILURE, WHICH COULD RESULT IN INJURY.

Panel Mount

Tube Length	A	B	C	D	E	F	G	H
65 MM	8 3/8 (212.7)	1 15/16 (49.2)	2 13/16 (71.4)	1 3/16 (30.2)	1 27/32 (46.8)	11/16 (17.5)	7 (177.8)	11/32 (8.7)
150 MM	11 15/16 (303.2)	1 15/16 (49.2)	2 13/16 (71.4)	1 3/16 (30.2)	1 27/32 (46.8)	11/16 (17.5)	10 9/16 (268.3)	11/32 (8.7)

Inline

Tube Length	A	B	C	D	E	F	G	H
65 MM	9 3/4 (247.7)	2 1/16 (52.4)	-	-	1 27/32 (46.8)	1 3/8 (34.9)	7 (177.8)	-
150 MM	13 15/16 (338.1)	2 1/16 (52.4)	-	-	1 27/32 (46.8)	1 3/8 (34.9)	10 9/16 (268.3)	-

3/8 FNPT FITTING 2 PLACES

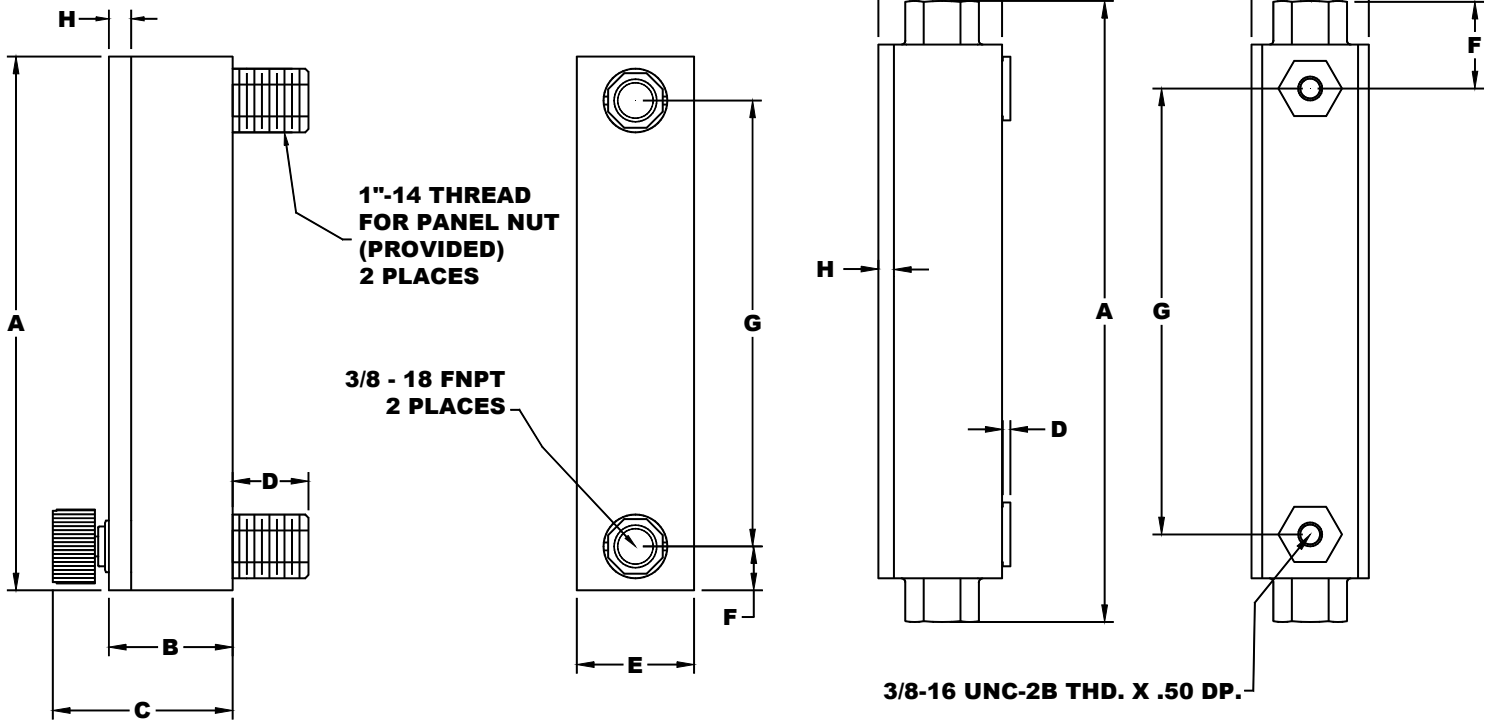

Panel Mount

Inline

CONTINUED PRODUCT IMPROVEMENT MAY RESULT IN SPECIFICATION REVISIONS
WHEN ORDERING PARTS PLEASE INCLUDE PART DESCRIPTION, ITEM NUMBER AND TYPE OF MATERIAL REQUIRED.