

Installation and Operation Manual

X-PR-5866E-5866M-eng

PN 541-C-005-AAA

April, 2008

Brooks® Compact Pressure Controller

Model 5866



Model 5866

Contents

Section 1 Introduction

	Page
Purpose	1-1
Description	1-1
Principle of Operation	1-1
Specifications	1-6
Controller Specifications	1-7

Section 2 Installation

Receipt of Equipment	2-1
Recommended Storage Practice	2-1
General	2-1
Gas Connections	2-1
Installation	2-2
In-Line Filter	2-3
Electrical Interface	2-3
Remote Setpoint (Command) Input	2-3
Valve Override	2-5
Precision 5V Reference	2-5
Remote Transducer Input	2-5
Valve Test Point	2-5
Optional Valve Return	2-6

Section 3 Operation

Operation	3-1
Proportional Band and Integration Time Constant Adjustment ...	3-1

Section 4 Maintenance

General	4-1
---------------	-----

Section 5 Troubleshooting

General	5-1
Troubleshooting	5-1
Disassembly	5-2
Assembly	5-5
Adjusting the Control Valve	5-6
Orifice Sizing	5-12

Section 6 Calibration

	<u>Page</u>
Calibration Procedure	6-1
Gas Conversion Factors	6-2

Section 7 Parts List

General	7-1
---------------	-----

Appendix A CE Certification

CE Certification for Mass Flow Equipment	A-1
--	-----

Figures

1-1	Model 5866 Pressure Transducer	1-2
1-2	Model 5866 Silicon Chip Configuration	1-2
1-3	Model 5866 System Block Diagram	1-2
1-4	Model 5866 Dimensions	1-3
1-5	Model 5866 Upstream Controller	1-4
1-6	Model 5866 Downstream Controller	1-4
1-7	Typical Application of Downstream Controller	1-5
1-8	Typical Application of Upstream Controller	1-6
2-1	Customer Connections and Settings	2-4
3-1	Error Signal Step Response	3-1
3-2	Proportional Control	3-3
3-3	Integral Control	3-3
3-4	P.I. Control	3-4
5-1	Torque Sequence for the Valve Retainer Plate	5-6
5-2	Adjustment Test Setup	5-7
5-3	Valve Adjusting Spacer Locations	5-9
5-4	Valve Adjusting Spacer Locations, Normally Open (N.O.) Valve	5-11
5-5	Application Configuration	5-12
5-6	Example Application of Orifice Sizing Procedure	5-14
7-1	Model 5866E Parts Drawing	7-2
7-2	Model 5866M Parts Drawing	7-4

Tables

2-1	D-Connector Pin Arrangement	2-5
5-1	Bench Troubleshooting	5-3
5-2	Sensor Troubleshooting	5-3
5-3	Minimum Flow Values	5-10
5-4	Model 5866 Orifice Selection	5-14
6-1	Conversion Factors	6-4
7-1	Model 5866E Parts List	7-3
7-2	Troubleshooting Aids and Spare Parts Kit for Model 5866	7-3
7-3	Model 5866M Parts List	7-5

1-1 Purpose

This instruction manual is intended to provide the user with all the information necessary to install, operate and maintain the Brooks® Model 5866 Pressure Controller. This manual is organized into seven sections:

- Section 1 - Introduction
- Section 2 - Installation
- Section 3 - Operation
- Section 4 - Maintenance
- Section 5 - Troubleshooting and Repair
- Section 6 - Calibration
- Section 7 - Spare Parts

It is recommended that this manual be read in its entirety before attempting to operate or repair the Model 5866.

1-2 Description

The Brooks Model 5866 Pressure Controller accurately measures and controls upstream or downstream pressures. The heart of the system is a solid state pressure transducer which produces an electrical output proportional to pressure. The electronics use this signal to operate the control valve and to provide an output signal.

1-3 Principle of Operation

The pressure to be measured acts on a stainless steel diaphragm. Via silicone oil, this pressure is transmitted to the actual sensing element, a silicon chip (refer to Figure 1-1). The chip consists of an anisotropically etched diaphragm with four piezo resistive resistors, configured in a Wheatstone bridge, etched into its surface (refer to Figure 1-2). The mechanical deformation of this diaphragm results in an imbalance of the resistors which is proportional to pressure. An amplifier provides output to the control circuit as well as the electrical output signal.

In addition to the pressure transducer the Model 5866 has an integral control valve and control circuitry. A difference between the pressure and setpoint signals will cause the electronics to modulate the control valve to maintain the desired pressure. A system block diagram is shown in Figure 1-3.

The integration of pressure transducer, control electronics and control valve into one unit results in a compact size. The mounting dimensions are comparable to a mass flow controller. Refer to Figure 1-4.

The “upstream pressure regulation mode” shown in Figure 1-5 places the pressure controller at the outlet of the pressure vessel. The pressure in the process upstream of the controller will be constant independent of downstream variation. Pressure measurement and control takes place at the outlet side of the pressure vessel.

Brooks Instrument Model 5866 Pressure Controller

Figure 1-1. Model 5866 Pressure Transducer.

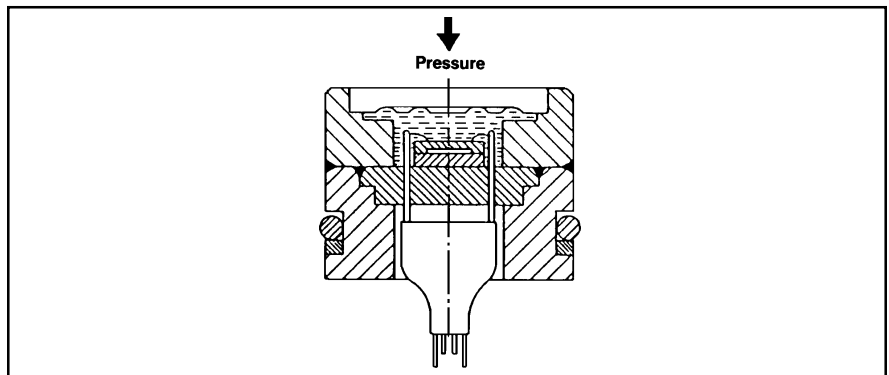

Figure 1-2. Model 5866 Silicon Chip Configuration.

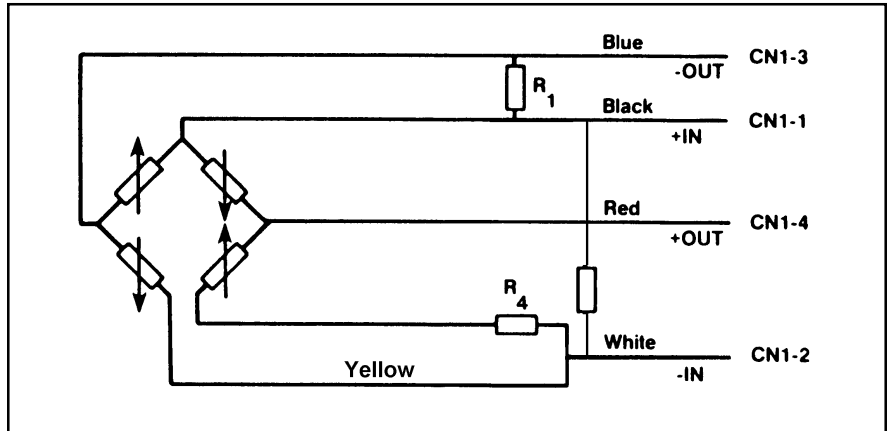

Figure 1-3. Model 5866 System Block Diagram (Downstream version).

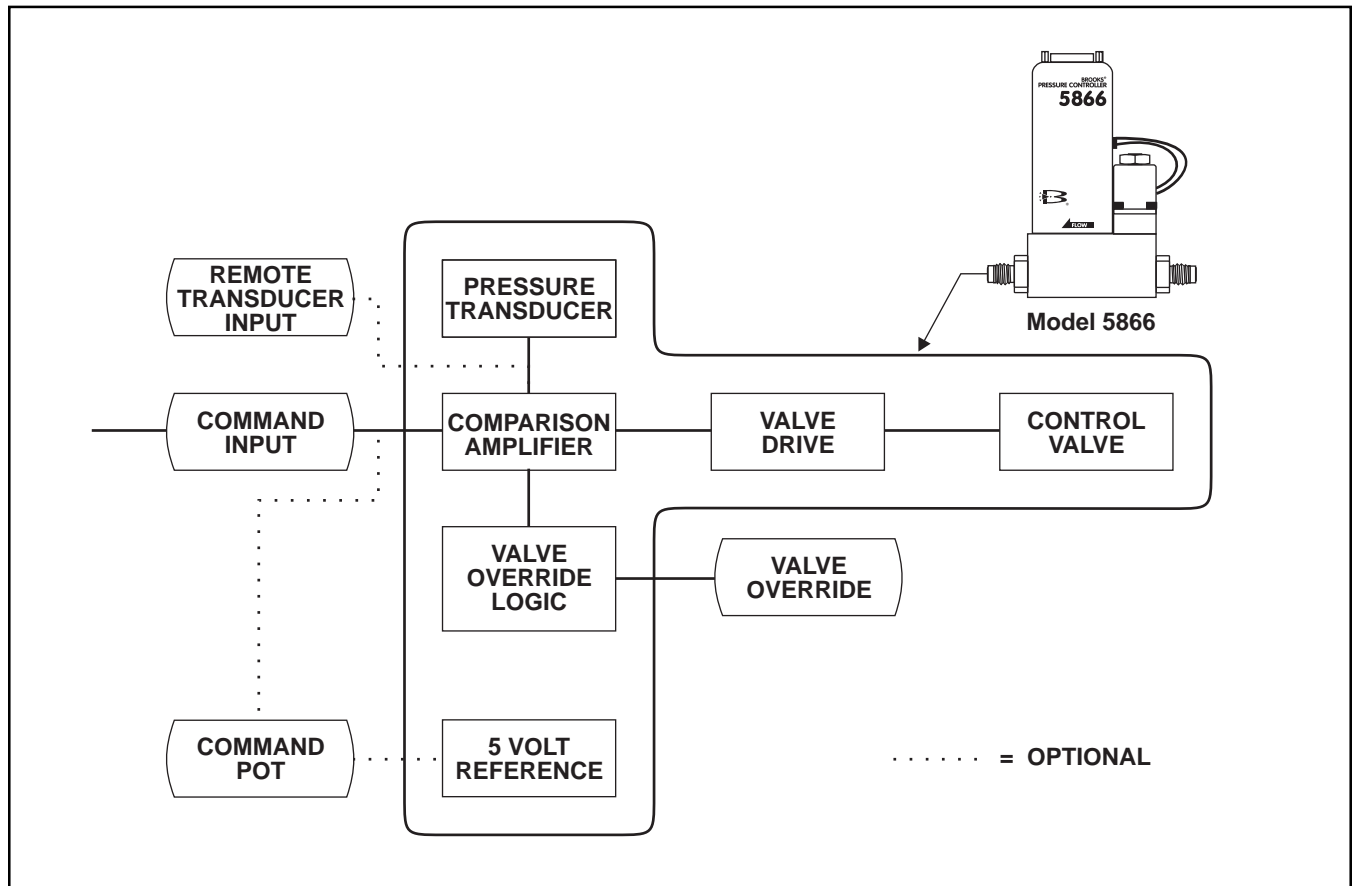
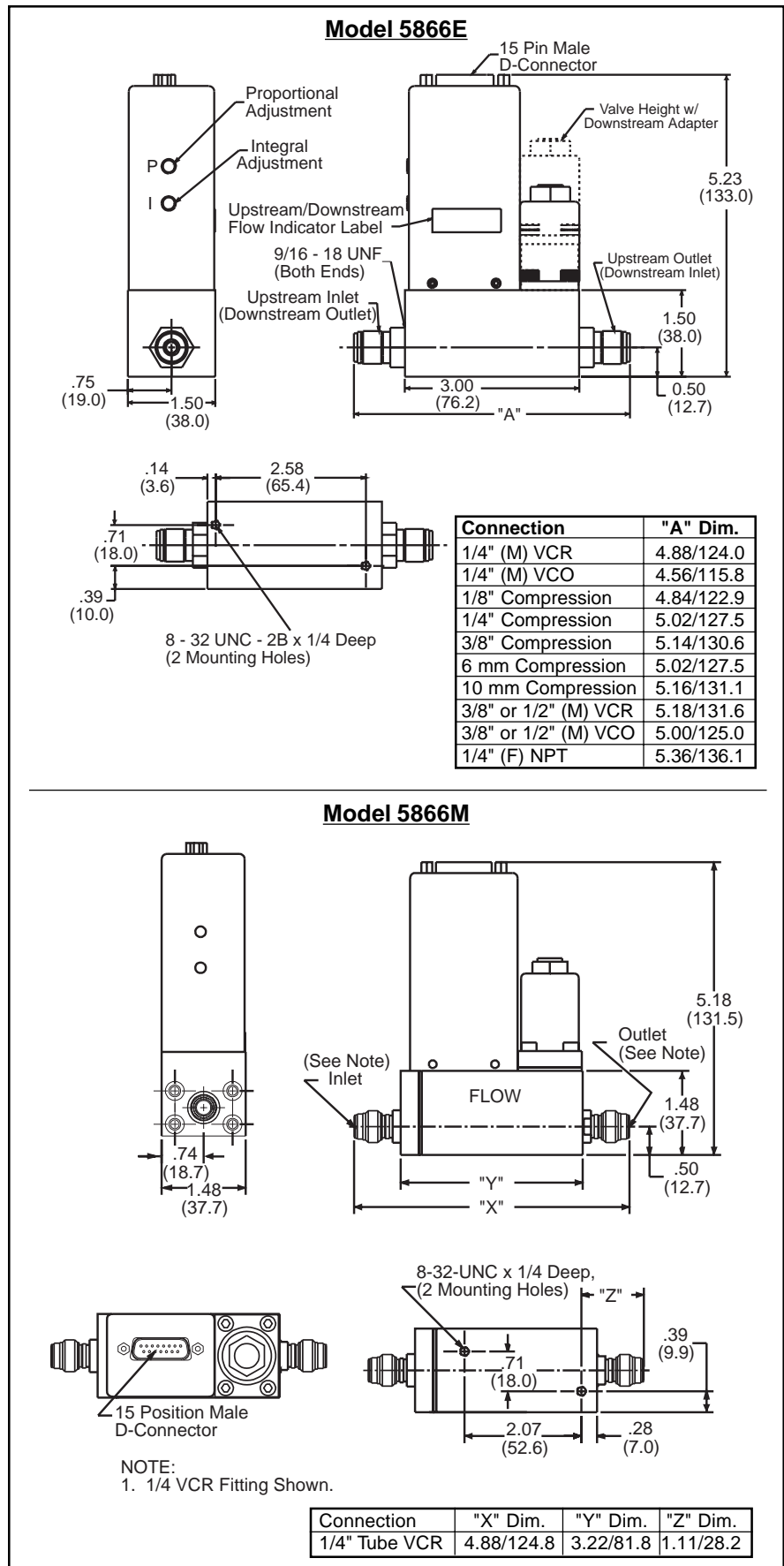

Figure 1-4. Model 5866 Dimensions.



When the pressure controller is used in the “downstream pressure regulation” mode as shown in Figure 1-6, the pressure in the process vessel will be constant independent of upstream variation, provided the upstream pressure does not fall below the downstream setting. Pressure measurement and control takes place at the inlet side of the pressure vessel.

The most common application of the pressure controller is in conjunction with a mass flow controller (refer to Figure 1-7). Mass flow controllers accurately measure and control the required quantity of process gas flows. In this figure, the mass flow controllers will supply the desired quantity and mixture of process gas while the pressure controller will maintain the desired reactor pressure by varying the gas outflow. This system allows the process reactants to be varied while maintaining a constant reaction pressure.

The Model 5866 Pressure Controller has proportional and integral control action. The reset or integral control is combined with the proportional control action (normally referred to as P.I. control). Both proportional band (0.5% to 100%) and integration time (0.05 to 5 seconds) are customer adjustable. Tuning of the pressure controller to perform as a stable optimum for each application is performed in-process by adjusting easily accessible P.I. action potentiometers (refer to Figure 1-4).

Note: The Controller Mode and valve type are determined at the time of order. Mechanical parts must be changed to convert modes or valve types.

Figure 1-5. Model 5866 Upstream Controller.

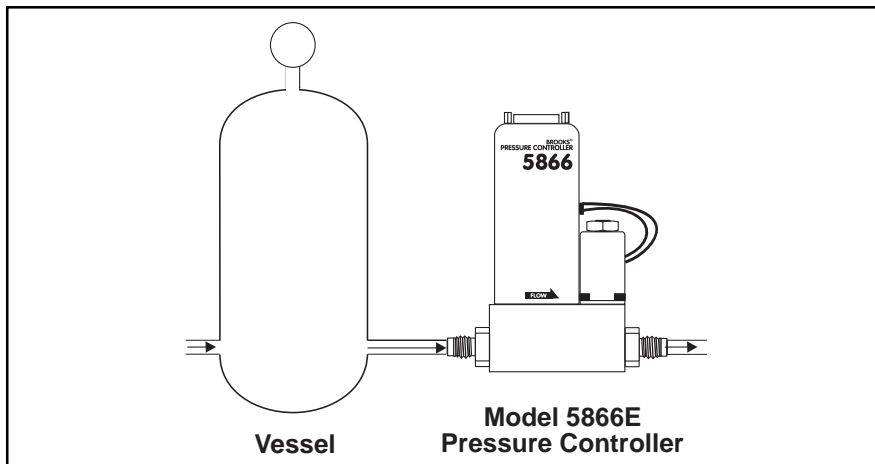
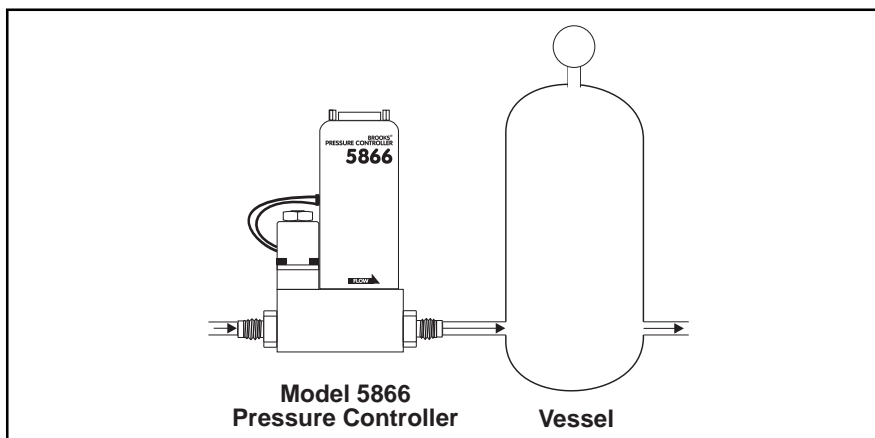

Figure 1-6. Model 5866 Downstream Controller.



Upstream Controller Mode sets the controller to maintain the upstream process pressure constant, independent of downstream pressure or flow variations (ref. Fig. 1-5). For jumper positions on the PC board see Figure 2-1.

Downstream Controller Mode sets the controller to maintain the downstream process pressure constant, independent of upstream pressure or flow variations. For jumper positions on the PC board, see Figure 2-1.

Normally Open/Normally Closed Control Valve - Both Normally Open (N.O.) and Normally Closed (N.C.) configurations are available. Normally Closed is the standard valve type. The Normally Open valve may be specified when Safety, Operation or Process considerations warrant this type of valve.

Remote Pressure Sensor Input allows the use of the integral control electronics and the valve to regulate the process pressure in response to the remote pressure transducer signal (refer to Section 2-11).

Voltage and Current Inputs/Outputs - Jumpers are provided on the PC board to allow 0-5 V, 0-10 V, 0-20 mA or 4-20 mA input/output. 0-5 V input/output is the standard configuration. For maximum accuracy, the Model 5866 should be calibrated with the input/output configuration it will ultimately use. Controllers will be configured at the factory if requested at the time of ordering.

Figure 1-7. Typical Application of Downstream Controller.

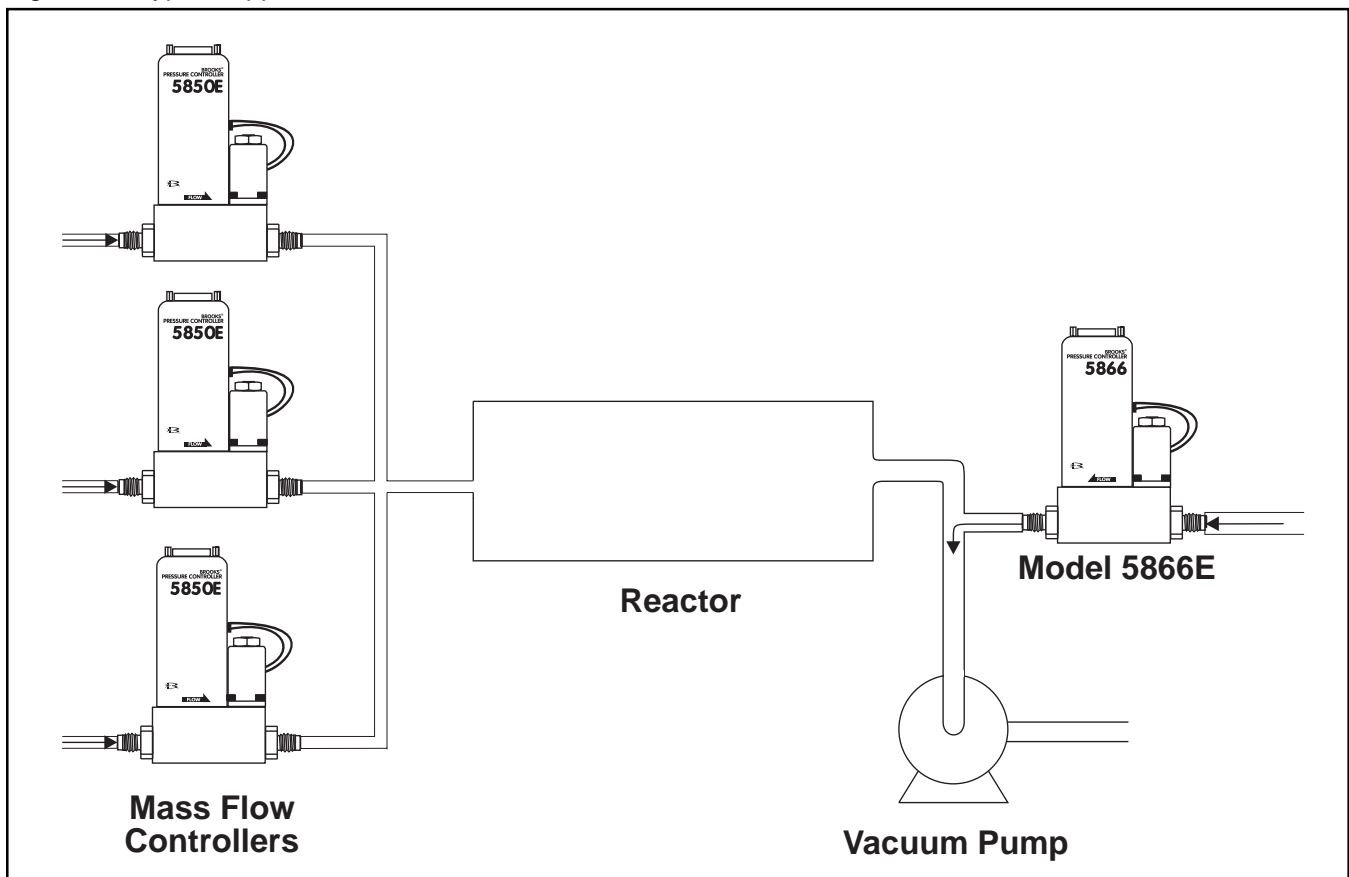

Valve Override permits the user to fully open and close the valve independent of the command setting (refer to Section 2-9).

Precision +5 Volt Reference is provided to be used in conjunction with a user supplied command potentiometer to generate a 0-5 V command signal.

1-4 Specifications

⚠ WARNING
Do not operate this instrument in excess of the specifications listed below. Failure to heed this warning can result in serious personal injury and/or damage to the equipment.

Pressure Ranges
7.25 psia to 1450 psia full scale (Elastomer Seals)
7.25 psia to 72.5 psia full scale (Metal Seals)

Figure 1-8. Typical Application of Upstream Controller.

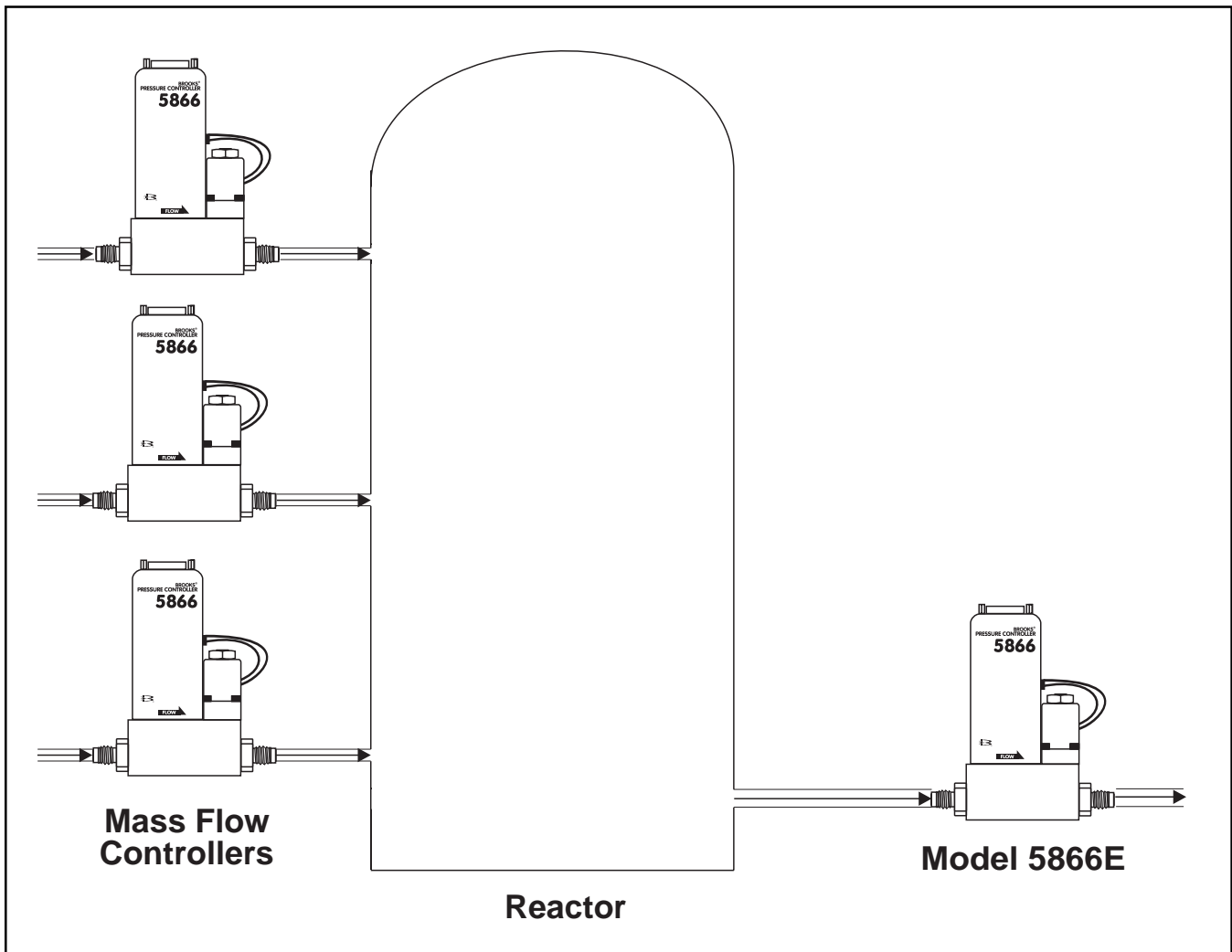

Flow Rates

0-30,000 sccm* (Nitrogen Equivalent).

*Standard pressure and temperature in accordance with SEMI (Semiconductor Equipment and Materials Institute) standard: 32°F (0°C) and 101 kPa (760 Torr). Other reference conditions available upon request.

Accuracy

±1.00% full scale including linearity and hysteresis

Repeatability

±0.1% full scale

Control Range

20:1

Zero Stability

0.001% full scale per 30 days

Temperature Range (ambient and gas)

32°F to 150°F (0°C to 65°C)

Temperature Coefficient

0.1% full scale/° C

Maximum Transducer Pressure

21.75 psia for 0-14.5 psia range

108.5 psia for 14.5-72.5 psia range

435 psia for 72.5-290 psia range

1,450 psia for 290-1,450 psia range

Maximum Design Pressure

1,450 psig

1-5 Controller Specifications

Input/Output Offset

< 0.2% full scale (voltage), < 1.5% full scale (current)

Proportional Gain

Adjustable, 1 to 200%

Integration Time

Adjustable, 0.05 to 5 seconds

Control Action

Upstream or downstream pressure control

Valve Type

Standard: Normally Closed

Optional: Normally Open

Materials of Construction

	Model 5866	Model 5866M
Wetted Parts	316 SS	316L Var SS
Seals/Valve Seats	Viton®	Metal
Options	Buna-N Teflon® Kalrez®	N/A

Brooks Instrument Model 5866 Pressure Controller

Power Requirements

N.C. 3.5 watts; +15 Vdc ($\pm 5\%$) @ 35 mA, -15 Vdc ($\pm 5\%$) @ 180 mA
N.O. 10.5 watts, ± 15 Vdc ($\pm 5\%$) @ 350 mA
Class III Equipment: The dc Mains input shall be supplied from a SELV (Separated Extra-Low Voltage) source.

Output Signals

Standard: 0-5 Vdc min load resistance 1 k ohm
Optional: 0-10 Vdc min load resistance 2 k ohm, 0 or 4-20 mA into maximum 500 ohm

5 Volt Reference Output

5 Volts $\pm 0.2\%$ min Load 1 k ohms.

Pressure Setpoint Signals

Standard: 0-5 Vdc input (impedance 1M ohm)
Optional: 0-10 Vdc input (impedance 1M ohm), 0 or 4-20 mA input (impedance 250 ohm)

Remote Pressure Sensor Input

Standard: 0-5 Vdc input (impedance 1M ohm)
Optional: 0-10 Vdc input (impedance 1M ohm)

Dimensions

Refer to Figure 1-4

Valve Type

Standard: Normally Closed
Optional: Normally Open

Process Connections

Standard: 1/4" stainless steel compression fittings
Optional: 1/4" VCR™, 1/4" VCO™, 1/8" compression

Electrical Connection

15 pin D-Connector (DA-15P)

Environmental Conditions

Installation Category: "I"
Pollution Degree: 2
Humidity: 50-80% Relative Humidity
Meter Altitude: 6562 feet (2,000 meters)
For Indoor Use ONLY
Mains supply voltage fluctuations not to exceed $\pm 10\%$ of the nominal voltage

Environmental Effects

EMC Effects Meets the requirement of the EMC directive
(89/336/EEC) EN 61000-4-2 thru 4-8
PED Sound Engineering Practice (SEP)

Area classification and certification

Area Certified for use in hazardous areas in Europe



II 3 G EEx nA II T4
KEMA 03ATEX1532 X
Per EN 60079-15:2003

The modules shall be installed in a suitable enclosure providing a degree of protection of at least IP54 according to EN 60529, taking into account the environmental conditions under which the equipment will be used.

2-1 Receipt of Equipment

When the equipment is received, the outside packing case should be checked for damage incurred during shipment. If the packing case is damaged, the local carrier should be notified at once regarding his liability. A report should be submitted to the Product Service Department, Brooks Instrument, 407 West Vine Street, Hatfield, Pennsylvania 19440.

Remove the envelope containing the packing list. Carefully remove the equipment from the packing case. Make sure spare parts are not discarded with the packing material. Inspect for damaged or missing parts.

2-2 Recommended Storage Practice

If intermediate or long term storage is required for the equipment, as supplied by Brooks Instrument, it is recommended that said equipment be stored in accordance with the following:

- a. Within the original shipping container.
- b. Store in a sheltered area with the following conditions:
 1. Ambient temperature 70°F (21°C) nominal, 90°F (32°C) maximum/45°F (7°C) minimum
 2. Relative humidity 45% nominal, 60% maximum 25% minimum.

Upon removal from storage, a visual inspection should be conducted to verify the condition of the equipment is "as received". If the equipment has been in storage for an excess of ten (10) months or under conditions in excess of those recommended, all pressure boundary seals should be replaced and the device subjected to a pneumatic pressure test in accordance with applicable vessel codes.

2-3 General

A pressure controller system can be built in upstream or downstream control configurations (refer to Figures 1-7 and 1-8). When the controller is placed downstream (upstream pressure controller) of the pressure vessel, the flow is usually determined by MFC(s) in the line upstream of the vessel.

With the pressure controller upstream of the vessel (downstream pressure controller), the most likely application is controlling a subatmospheric pressure in the vessel. The inlet of the pressure controller can be at atmospheric gas pressure or at vapor pressure of a liquid source. The flow in this situation is usually determined by the characteristics of a vacuum pump.

2-4 Gas Connections

Standard inlet and outlet connections on the Model 5866 and 1/4" compression fittings. Optional VCO™ and VCR™ connections are available upon request.

Prior to installation, insure that all piping is clean and free of obstructions. Install the piping in such a manner that permits easy removal if the instrument is to be removed for cleaning or test bench troubleshooting.

2-5 Installation

⚠ WARNING

Do not operate this instrument in excess of specifications. Failure to heed this warning can result in serious personal injury and/or damage to the equipment.

⚠ CAUTION

When installing the instrument, insure that no foreign materials enter the inlet or outlet of the meter. Do not remove the protective end caps until time of installation.

⚠ CAUTION

Any Brooks Instrument mass flow meter or flow controller with a 15 pin D-Connector PC Board bearing the "CE Mark" must use a 100% shielded cable and metal shell mating connectors. The shield is tied over 360 degrees to the shell at both ends. This is mandatory to be in compliance with the EMC Directive (89/336/EEC). Refer to Appendix A.

Recommended Installation Procedures

- a. The Model 5866 should be located in a clean, dry atmosphere relatively free from shock and vibration.
- b. Leave sufficient room for access to the electrical components.
- c. Install in such a manner that permits easy removal if the instrument requires cleaning.

⚠ CAUTION

When used with a reactive (sometimes toxic) gas, contamination or corrosion may occur as a result of plumbing leaks or improper purging. Plumbing should be checked carefully for leaks and the controller purged with dry nitrogen before use. See Brooks' Technical Bulletin T-086 for further information.

- d. The Model 5866 pressure controller may be installed in any position.

Note: The control valve in the Model 5866 provides precision control and is not designed for positive shut-off. If positive shut-off is required, it is recommended that a separate shut-off valve be installed in-line.

⚠ CAUTION

Since the Model 5866 Control Valve is not a positive shut-off, a separate solenoid valve may have been installed for that purpose. It should be noted that a small amount of gas may be trapped between the downstream side of the pressure controller and the solenoid, resulting in a surge upon opening of the solenoid valve. This surge can be reduced in magnitude by locating the controller and solenoid valve close together or by moving the solenoid valve upstream of the controller.

2-6 In-Line Filter

It is recommended that an in-line filter, such as the Brooks Model 5848, be installed upstream from the controller to prevent the possibility of any foreign material entering the meter. The filter porosity should be approximately ten times smaller than the orifice used in the installation, however, it is recommended that the minimum porosity that does not restrict the flow rate being used. The filtering element should be periodically replaced or cleaned.

2-7 Electrical Interface

To insure proper operation, the Model 5866 must be connected per Figure 2-1. As a minimum, the following connections must be made for new installations.

Pin Number	Description
1	Command Common
2 or 4	Signal Output
5	+15 Vdc Supply
6	-15 Vdc Supply
8	Command Input
9	Supply Voltage Common
10	Voltage Signal Common
13	+15 Vdc Supply (Current I/O)

Note: The Command Return is internally connected to Signal Return and Supply Voltage Common.

2-8 Remote Setpoint (Command) Input

If the pressure controller will be commanded by an external voltage or current signal, the command potentiometer is not used.

The command hookup is as follows:

- a. Voltage Signal: Connect the external command signal to Terminal 8 and the external command return to Terminal 1. Refer to Figure 2-1 and Table 2-1.
- b. Current Signal: Connect the command signal to Terminal 8 and the command return to Terminal 1. Jumper J4 should be ON. Refer to Figure 2-1 and Table 2-1.

Note: The command return is internally connected to signal return and power supply common. Current supplied by the device providing the set point will not be returned on the current loop.

Figure 2-1. Customer Connections and Settings.

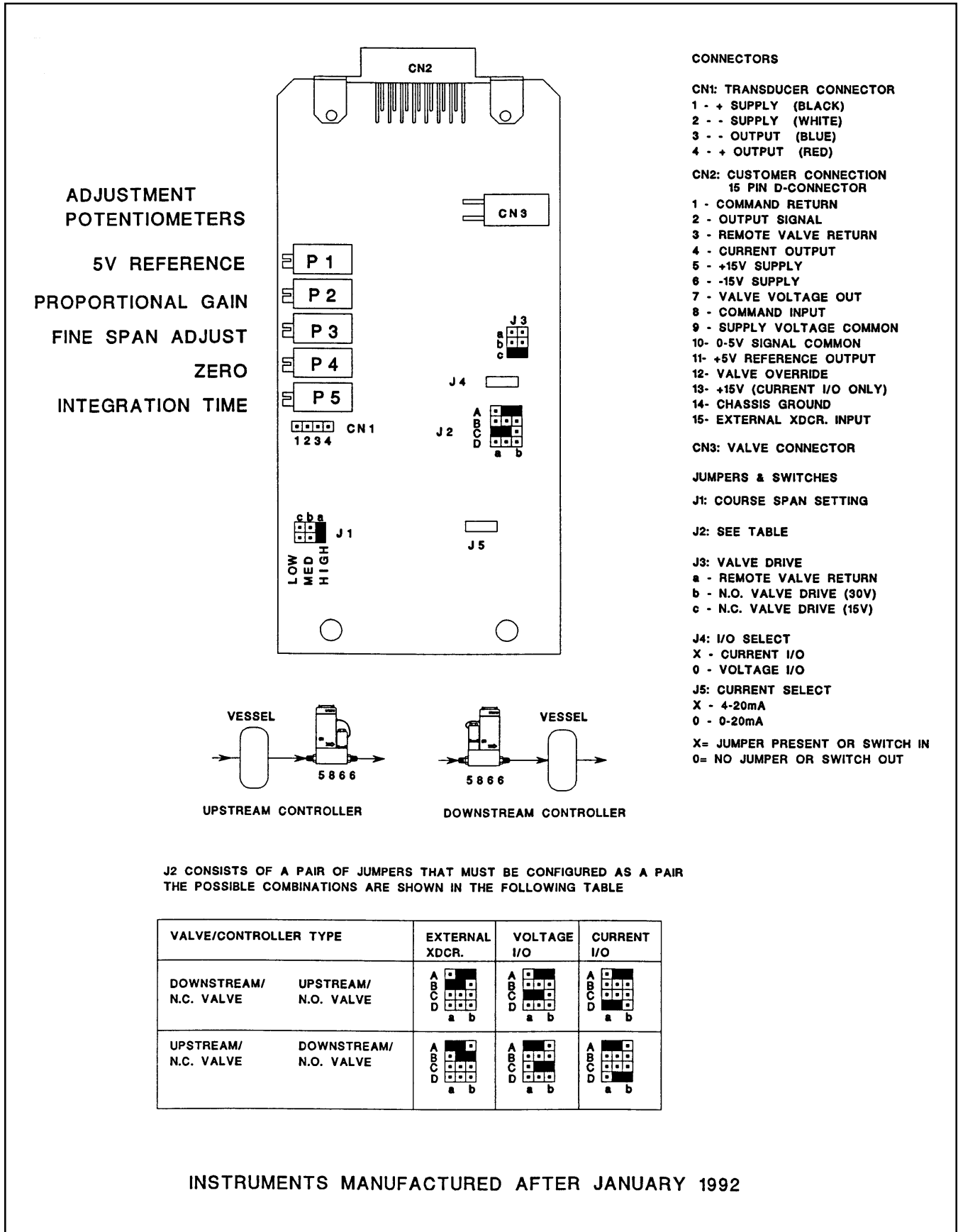
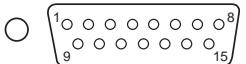

Table 2-1. D-Connector Pin Arrangement.

PIN NO.	FUNCTION	COLOR CODE
1	Command Common (Command Pot "CCW")	Black
2	Voltage Signal Output	White
3	Remote Valve Return	Red
4	Current Output	Green
5	+15 Vdc Supply	Orange
6	-15 Vdc Supply	Blue
7	Valve Voltage Out/External Valve Control	Wht/Blk
8	Command Input (Command Pot "S")	Red/Blk
9	Supply Voltage Common	Grn/Blk
10	Voltage Signal Common	Org/Blk
11	+5 Volt Reference (Command Pot "CW")	Blu/Blk
12	Valve Override	Blk/Wht
13	+15 Vdc Supply (1)	Red/Wht
14	Chassis Ground (2)	Grn/Wht
15	External Sensor Input	Blu/Wht



NOTES:

- Pin 13 does not have to be connected if current I/O is not used.
- Cable shield tied to chassis ground in meter connector.

2-9 Valve Override

The valve override function allows full opening and closing of the valve independent of the command setting.

The valve override for the pressure controller is as follows:

- To open the valve, apply +15 Vdc to the valve override terminal.
- To close the valve, apply -15 Vdc to the valve override terminal.

The valve override function is accessed from Terminal 12 (refer to Figure 2-1 and Table 2-1).

Note: For normal operation, Terminal 12 may be left open (floating) or grounded.

2-10 Precision 5V Reference

The Model 5866 is equipped with a precision 5 Vdc reference. The reference is used internally for precise zero adjustment and is also available as a buffered output for use in conjunction with a 1 to 10 k ohm potentiometer to provide 0-5 Vdc set-point. The 5 Vdc reference is available at Terminal 11 (refer to Figure 2-1 and Table 2-1).

2-11 Remote Transducer Input

To allow the Model 5866 control circuitry and valve to be used with an external transducer signal such as a capacitance manometer, Jumper J2 "C" or "D" must be moved to the Position B. Jumper J2, "A" can be in either Position a or b depending on valve/controller type. The external sensor signal (0-5 or 0-10 Vdc) must be connected to Terminals 15 and 10 (refer to Figure 2-1 and Table 2-1).

2-12 Valve Test Point

The valve voltage may be monitored on Terminal 7 of the D-Connector.

2-13 Optional Valve Return

Units manufactured after January, 1992 with a Normally Closed valve can be configured so the valve current can be returned to the power supply on a separate line. This is recommended if the power supply lines are longer than 10 feet. The feature is enabled by connecting Pin 3 of the D-Connector to power supply common with a separate lead and moving Jumper J3 to the Position a.

3-1 Operation

- a. Purge the system with dry nitrogen for at least thirty minutes prior to start-up to prevent the formation of deposits if reactive gas is to be used.
- b. In unpressurized piping, apply power to the controller and allow approximately fifteen minutes for it to warm up and stabilize its temperature.
- c. Slowly apply gas pressure to the system.
- d. Set the command for the desired pressure to assume normal operation.

3-2 Proportional Band and Integration Time Constant Adjustment

The Model 5866 Pressure Controller has proportional and integral control action. The reset, or integral, control is combined with the proportional control actions, commonly referred to as P.I. control. Both proportional band and integration time are user adjustable. Refer to Figure 1-4 for P and I adjustment potentiometer locations. The dynamic behavior of the control system is influenced by flow range, pressure range, fluid type, orifice size and system volume. Therefore, Model 5866 may have to be adjusted in the field to achieve the best dynamic response.

The factory settings are typically: proportional band minimum, 0.5%, potentiometer fully counterclockwise (c.c.w.) and integration time minimum, 0.05 seconds, potentiometer fully clockwise (c.w.). This combination of adjustments usually results in stable control. For most systems the dynamic response is adequate with the factory settings. Improved response can be had by final tuning the P and I potentiometers in the system by the user. The tuning of the P and I constants does not affect the calibration of the instrument.

Definitions

Both proportional and integral control actions are defined with respect to a step response error signal. Refer to Figure 3-1.

Figure 3-1. Error Signal Step Response.

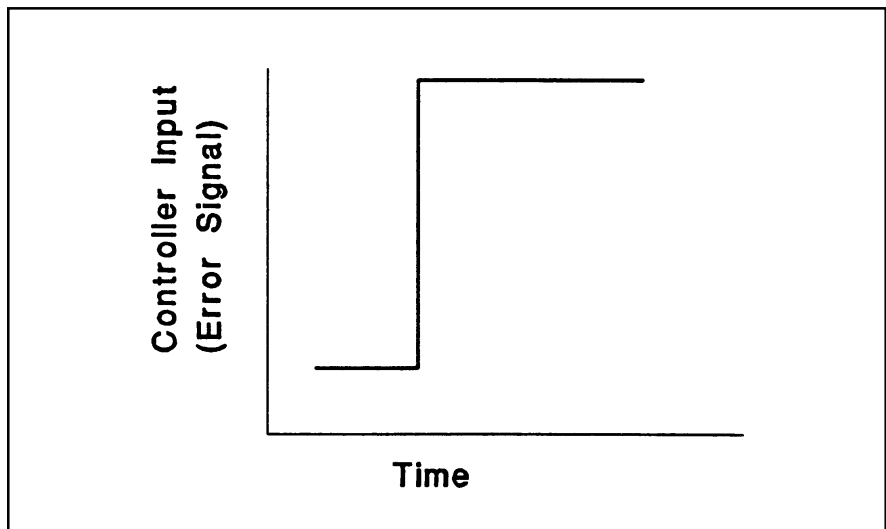

Proportional Control

Proportional control is a basic continuous control mode in which the controller output is proportional to the error input signal to the controller. Refer to Figure 3-2. It provides very rapid response and is relatively stable. Used alone, proportional control has one major disadvantage: at steady state it exhibits an offset. That is there is a difference between the desired value, or setpoint and the actual value of the controlled variable. An integral action added to the proportional mode eliminates offset.

Integral Control

Integral or reset action is an integration of the input error signal over time. Refer to Figure 3-3. This means that with integral action the value of the manipulated variable changes at a rate proportional to the error. With integral action present there can be no offset at steady state since the manipulated variable will continue to change as long as an error is present.

Characteristics of P.I. Control

By using both proportional and integral control actions, rapid control can be achieved with out a steady state offset. Refer to Figure 3-4. Typically there is a slight decrease in system stability due to the presence of the integral mode. The dynamic response of the system is better than the response would be with integral alone. Because the two controller modes are interactive the P.I. controller is somewhat more difficult to tune.

Tuning the P.I. control

Turning the P potentiometer clockwise (c.w.) will increase the proportional band thus increasing the offset and system response time. If the proportional band is too low, the system may overshoot the command, or oscillate. Turning the I potentiometer counterclockwise (c.c.w.) will increase the integration time, making the system respond slower, but more stable.

Adjust the P and I potentiometers until the optimum response is achieved. Check the adjustment in the system over the expected range of pressures and flows.

Fastest controller response to set point changes are obtained with the P potentiometer fully counterclockwise and the I potentiometer fully clockwise.

Figure 3-2. Proportional Control.

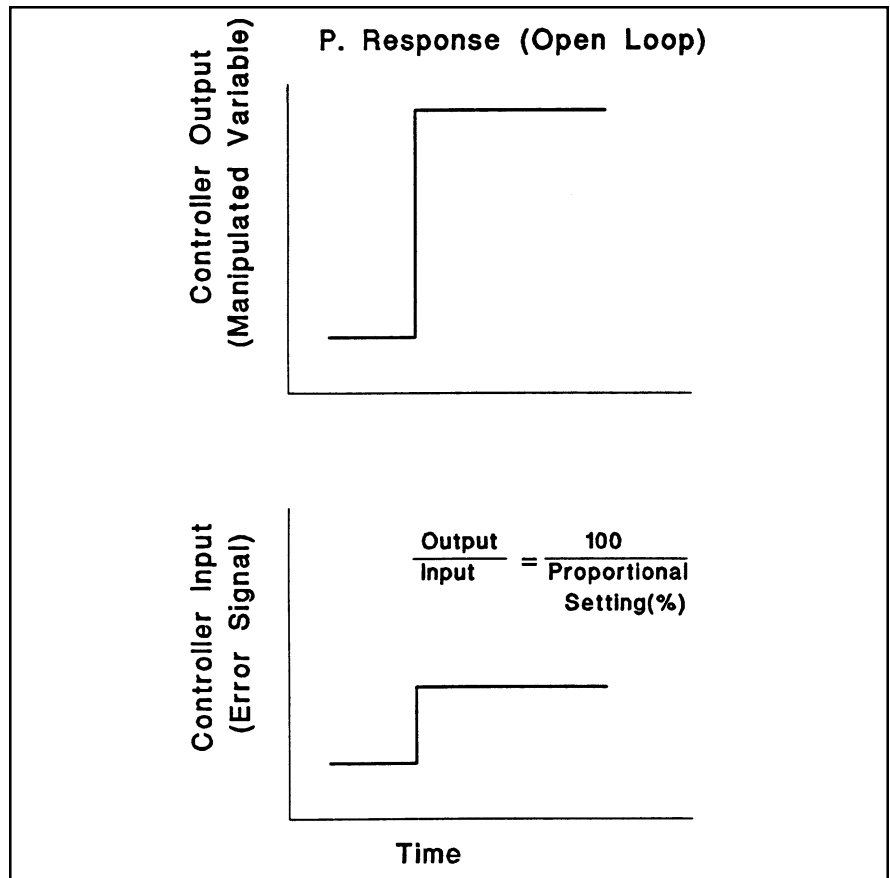

Figure 3-3. Integral Control.

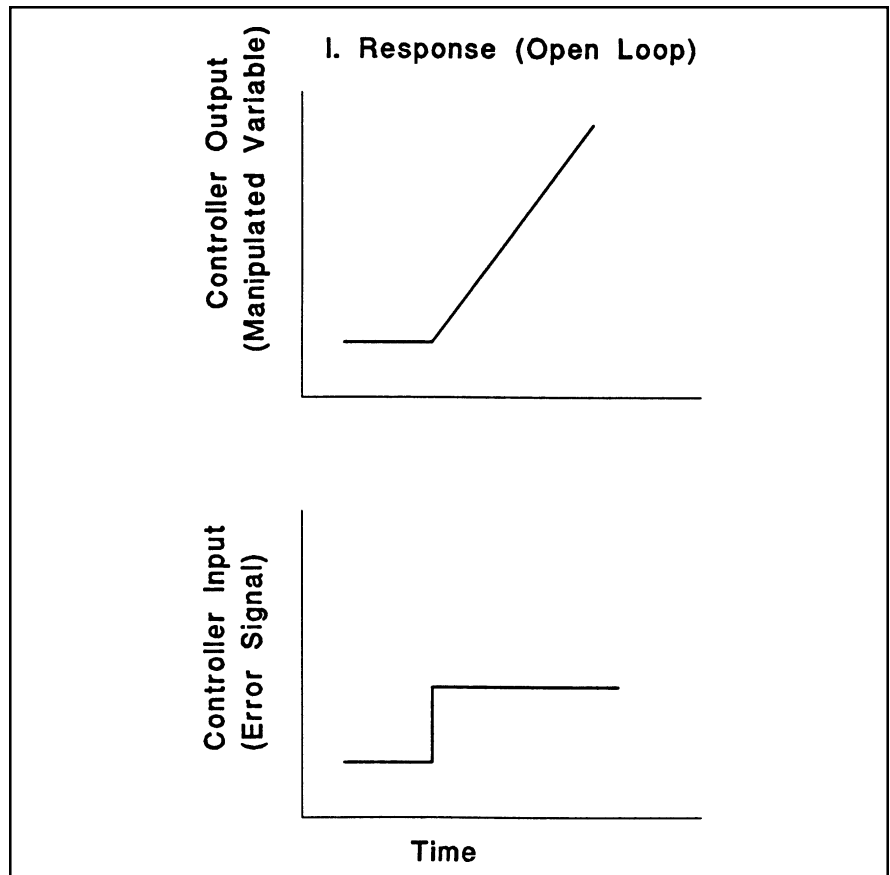
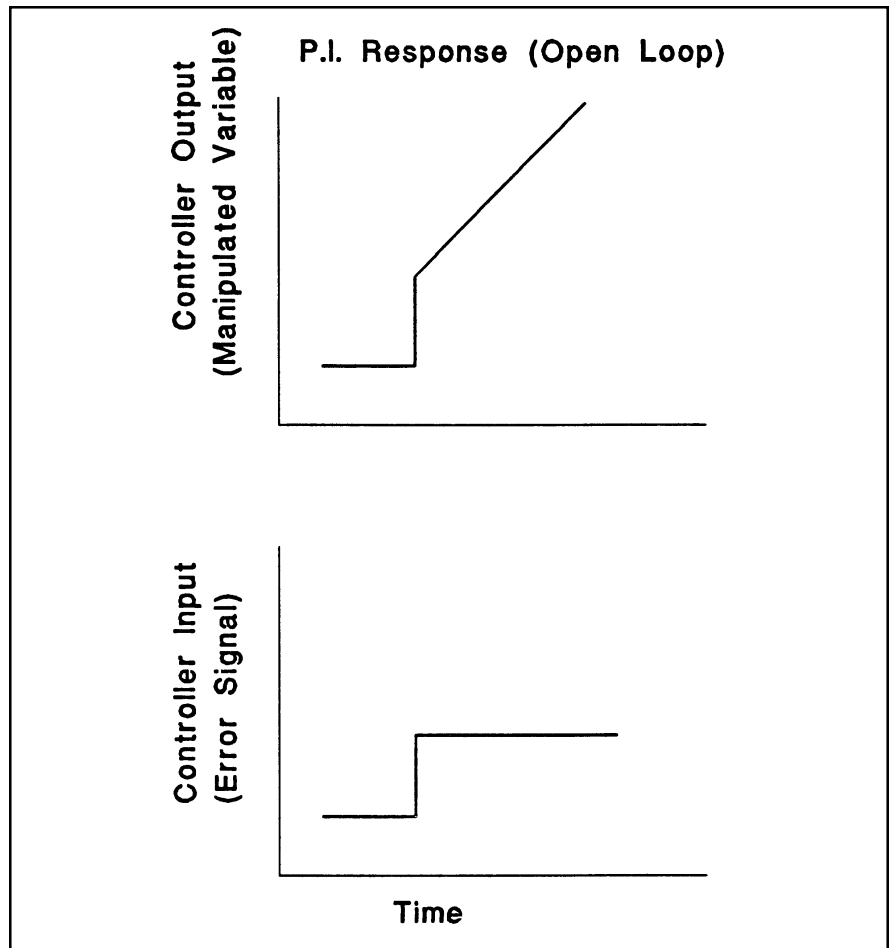

Figure 3-4. P.I. Control.



4-1 General

No routine external maintenance is required for Brooks thermal mass flow controller. If an in-line filter is used for the Model 5866, the filtering element should periodically be replaced or cleaned.

5-1 General

⚠ CAUTION

It is important that this controller be serviced only by properly trained and qualified personnel.

A. System Checks

The Model 5866 is generally used as a component in gas handling systems which can be quite complex. This can make the task of isolating a malfunction in the system a difficult one. An incorrectly diagnosed malfunction can cause many hours of unnecessary down time. If possible, make the following system checks before removing a suspected defective pressure controller for bench troubleshooting or return to the factory, especially if the system is new.

1. Verify a low resistance common connection and that the correct power supply voltage and signals are reaching and leaving the controller. The Break-out Board (P/N S-273-Z-649-AAA) will make this job much easier.
2. Verify that the process gas connections have been correctly terminated and leak checked.
3. If the pressure controller appears to be functioning but cannot achieve set-point, verify that sufficient inlet pressure and pressure drop are available at the controller to provide the required flow.
4. Verify that all user selectable jumpers are in their desired positions (refer to Figure 2-1).

⚠ WARNING

If it becomes necessary to remove the controller from the system after exposure to toxic, pyrophoric, flammable or corrosive gas, purge the controller thoroughly with a dry inert gas such as nitrogen before disconnecting the gas connections. Failure to correctly purge the controller could result in fire, explosion or death. Corrosion or contamination of the pressure controller upon exposure to air may also occur.

5-2 Troubleshooting

A. Bench Troubleshooting (Table 5-1)

1. Connect the pressure controller to a ± 15 Vdc power supply, and a command voltage source. Connect an output signal readout device (a 4-1/2 digit voltmeter is recommended) to Terminals 2 and 10 (refer to Table 2-1).
2. Apply power to the controller, close the valve using the valve override closed input and allow it to warm up for fifteen minutes. Do not connect the controller to a gas source at this time.

3. Observe the output signal and, if necessary, perform the zero adjustment procedure, Section 6.
4. If the output signal will not zero properly, troubleshoot the sensor using the procedures given in Section 5-2B. If the sensor is electrically functional, the printed circuit board is defective and will require replacement.
5. Connect the controller to a source of the gas it is calibrated for. Command 100% pressure and adjust the inlet and outlet pressures to the calibration conditions. Verify that the output signal reaches and stabilizes at 5.00 Volts.
6. Vary the command voltage over the 5 to 100% range and verify the output signal follows the set-point.

B. Transducer Troubleshooting (Table 5-2)

1. Troubleshoot the transducer using the steps given in Table 5-2. If any of the steps do not give the expected result, the transducer assembly is defective and must be replaced.
2. If the transducer is defective, refer to Sections 5-3 and 5-4 for the disassembly and assembly procedures for replacing the transducer.

Note: Do not attempt to disassemble the transducer.

5-3 Disassembly

The Model 5866 pressure controller may be disassembled in the field by the user for cleaning, re-ranging or servicing. The disassembly procedures below detail the upstream control version of the Model 5866 with a Normally Closed control valve. The procedures for the upstream control version and the Normally Open control valve are substantially the same. Disassemble the controller as follows:

Note: The controller should be disassembled in a clean environment to prevent contamination.

⚠ CAUTION

Do not attempt to disassemble the controller until pressure has been removed and purging has been performed.

A. Disassembly Procedure [numbers in () refer to Figure 7-1]

1. Remove the jam nut (1) on top of the valve assembly.
2. Unplug the valve connector from the electronics cover and remove the coil assembly (2).
3. Remove the hex socket screws (3) securing the valve retaining plate (4) attaching the valve stem assembly (6).

⚠ CAUTION

When performing the following procedure, the valve stem must be removed without cocking it to prevent damage to the valve spring.

4. Carefully remove the valve stem assembly (6).
5. Remove the plunger assembly (7, 8, 9 and 11).
6. Remove and note the position of the valve spring spacers (10). Spacers may be used above and/or below the lower valve springs (8).
7. Unscrew the orifice (12) from the flow controller body (25).

Table 5-1. Bench Troubleshooting.

Trouble	Possible Cause	Check/Corrective Action
Output stays at zero Volts regardless of command and there is pressure on the controller.	Defective Sensor	Replace sensor. Refer to Section 5-3 and Table 5-2.
Output stays at zero Volts regardless of command and there is no flow through the controller.	Clogged Control Valve	Check Pin 7 if the voltage is more than +11 V. Disassemble and repair the control valve. Refer to Sections 5-3 and 5-4.
	-15 V applied to the valve override input. Defective printed circuit board.	Check valve override input. Refer to Figure 2-2 for terminal assignments. Replace printed circuit board. Refer to Sections 5-3 and 5-4.
Output signal stays at +14 V. regardless of command and there is flow through the controller.	Valve stuck open or leaky.	Clean and/or adjust control valve. Refer to cleaning procedure and/or Section 5-5.
	+15 Vdc applied to the valve override input.	Check the valve override terminal. Refer to Figure 2-2 for terminal assignments.
	Defective printed circuit board	Replace printed circuit board. Refer to Sections 5-3 and 5-4.
	Command input floating.	Connect command signal. Refer to Figures 2-1 and 2-2 for terminal assignments.
Output signal follows setpoint at higher commands but will not go to zero.	Leaky control valve.	Disassemble and repair valve. Refer to Sections 5-3 and 5-4.
	Excessive resistance in valve voltage return line.	Reduce wiring resistance
Output signal follows setpoint at lower commands but does not reach full scale.	Insufficient inlet pressure or pressure drop	Adjust pressures, check calibration. Refer to Section 5-1.
	Partially clogged valve.	Disassemble and repair control valve. Refer to Sections 5-3 and 5-4.
	Valve out of adjustment.	Adjust valve. Refer to Section 5-5.
	Valve guide spring failure.	Controller oscillates (see below)
Controller oscillates.	Pressure drop or inlet pressure excessive.	Adjust pressures.
	Oversized orifice	Check orifice size. Refer to Section 5-6 and Table 5-4.
	Valve out of adjustment.	Adjust valve. Refer to Section 5-5.
	P/I adjustment not correct.	Adjust P/I potentiometers. Refer to Section 3-2.
	Faulty pressure regulator.	Check regulator output.
	Defective printed circuit board	Replace printed circuit board. Refer to Sections 5-3 and 5-4.

Table 5-2. Sensor Troubleshooting.

to P.C. Board
CN1

OHMMETER CONNECTION	RESULT IF ELECTRICALLY FUNCTIONAL
4 Sensor wires to body (ground) (Pin 1 to 4 to body)	Open circuit on Ohmmeter. If one of these is shorted, an Ohmmeter reading will be obtained.
Between the different wires	Minimum 1 k Ohm Maximum 4 k Ohm Depending on sensor used
NOTE: Remove the sensor connector from the P.C. board for this procedure.	

8. Remove the three screws (29) and jack posts (32) attaching the electronics cover. Remove the electronics cover (31).

⚠ CAUTION

Be careful not to stress the transducer lead wires to transducer assembly junction when removing the sensor connector from the printed circuit board. If the transducer lead wires are stressed, an open in the transducer wiring could result.

9. Unplug the sensor connector from the printed circuit board. Remove the two screws (29) securing the bracket (28) and printed circuit board (30). Remove the bracket and board.

⚠ WARNING

Do not remove the transducer before reading the following instructions. Failure to heed this warning can result in personal injury.

10. Transducer removal should be avoided. The Model 5866 pressure transducer is not serviceable and only needs to be removed when the transducer is replaced or when the O-rings are replaced. Transducer removal will require the use of compressed gas to force the transducer from the body. This pressure may exceed the maximum withstand pressure of the transducer, creating the need for adjustment or replacement. Be sure the transducer needs to be removed before proceeding.
11. Remove the two screws (3) from the base plate (27) then reinstall them 2-3 turns into the body. Reinstall the valve stem (6), retaining plate (4) using the four hex socket screws (3). Cap the outlet port.

⚠ WARNING

The screws (3) are to be reinstalled to prevent violent ejection of the transducer when the pressure is applied. Personal injury can result if the transducer is not captured by these loose screws.

12. Slowly pressurize the inlet port to force the transducer (26) from the body (25) and against the loosened base plate (27). Remove the pressure once the transducer (26) is against the base plate (27). Remove the base plate (27), transducer (26) and valve stem (6) from the body (25.)

⚠ CAUTION

Do not scratch the transducer O-ring sealing surfaces or touch the transducer diaphragm surface.

13. Remove the O-ring (5) from the transducer assembly (26). The Teflon backup ring may remain in place.

Note: Steps 10, 11, 12 and 13 may be eliminated if the transducer is not to be removed.

B. Cleaning Procedures

Should the Model 5866 Pressure Controller require cleaning due to contamination with foreign material, use the following procedures:

1. Remove the unit from the system.
2. Refer to Section 5-3 to disassemble the controller.

⚠ CAUTION

Do not soak the pressure transducer assembly in a cleaning solution. If solvent seeps into the transducer assembly, it may damage the transducer or, at least, significantly alter its operating characteristics.

3. Inspect the orifice for clogging by holding it in front of a light source and looking for light through the bore. Clean by soaking in a suitable non-residuous solvent and directing a stream of compressed dry nitrogen through the bore.
4. Deposits of silicon dioxide may be removed by soaking the internal parts in a solution of 5% hydrofluoric acid (5 parts hydrofluoric (HF), 95 parts water (H₂O) followed by Freon TF™.
5. Blow all parts dry with dry nitrogen and reassemble. Refer to Section 5-4 Assembly Procedure.
6. Purge the assembled controller with dry nitrogen.
7. Perform calibration procedure in Section 6 if needed.
8. When the controller is reinstalled in the system, the connections should be leak-tested and the system should be purged with dry nitrogen or argon for thirty minutes prior to start-up to prevent the formation of deposits.

5-4 Assembly

The assembly procedures below detail the downstream control version of the Model 5866 with a Normally Closed control valve. The procedures for the upstream control version and the Normally Open control valve are substantially the same.

⚠ CAUTION

Do not get halocarbon grease on the hands. This is a special inert lubricant which is not easily removed.

Note: It is recommended that all O-rings be replaced during assembly. All O-rings should be lightly lubricated with halocarbon lubricant prior to their installation.

Note: Gloves should be worn to reduce the possibility of contaminating the Model 5866 or process.

A. Assembly Procedure [numbers in () refer to Fig. 7-1]

1. Examine all parts for signs of wear or damage, replace as necessary.
2. Install the transducer O-ring (5) on the transducer assembly (26). The O-ring (5) is placed below (process side) the Teflon backup ring on the transducer.
3. Install the transducer (26) and base plate (27), securing it with two screws (3) tightened to 15 in/lbs.

Note: The orifice can easily become clogged with skin or other foreign matter during assembly. Do not touch the orifice with the bare hand during installation. Use rubber gloves, finger cotts or pliers to start the orifice in the body.

4. Install the orifice (12) and its O-ring (13) using a 3/8" nut driver. Insure that the orifice is fully seated but do not overtighten.
5. Insert the valve preload spacers (10), if used, into the valve cavity in the controller body (25). Use care to preserve the correct order.
6. Install the valve plunger assembly (7, 8, 9 and 11) on the preload spacers (10). Install air gap spacers, if used, on top of the valve springs.
7. Install the valve stem assembly (6), secure with the valve retaining plate (4) and four hex socket screws (3). When installing the screws, insure that the plate makes full contact all the way around the stem. Torque the screws, securing the retaining plate in a diagonal pattern (refer to Figure 5-1) to 15 in-lbs.
8. Install the coil assembly (2) over the valve stem assembly (6) and secure with jam nut (1).
9. Install the printed circuit board (30), secure with the bracket (28) and two screws (29). Plug the connector from the sensor onto the printed circuit board.
10. Install the electronics cover (31) on the controller, secure with three screws (29) and two standoffs (33). Plug the connector from the valve coil into the printed circuit board through the hole in the electronics cover.
11. Prior to installation, leak and pressure test the controller to any applicable pressure for the transducer (refer to Section 4-1).

5-5 Adjusting the Control Valve [numbers in () refer to Figure 7-1]

The Model 5866 control valve has been factory adjusted to insure proper operation. Adjustment is not normally required during the life of the instrument. Readjustment may be required if any of the following parts have been replaced:

Normally Closed Valve

- Orifice (12)
- Valve Stem (6)
- Plunger (7)
- Lower Guide Spring(s) (8)
- Valve Seat (11)
- Downstream Control Adaptor (21)

Normally Open Valve

- Orifice (12)
- Valve Stem (15)
- Plunger (16)
- Lower Guide Spring (8)
- Valve Seat (11)
- Downstream Control Adaptor (21)
- Plunger Extension (18)
- Spring Spacer (19)
- Insert Sleeve (17)

Figure 5-1. Torque Sequence for the Valve Retainer Plate.

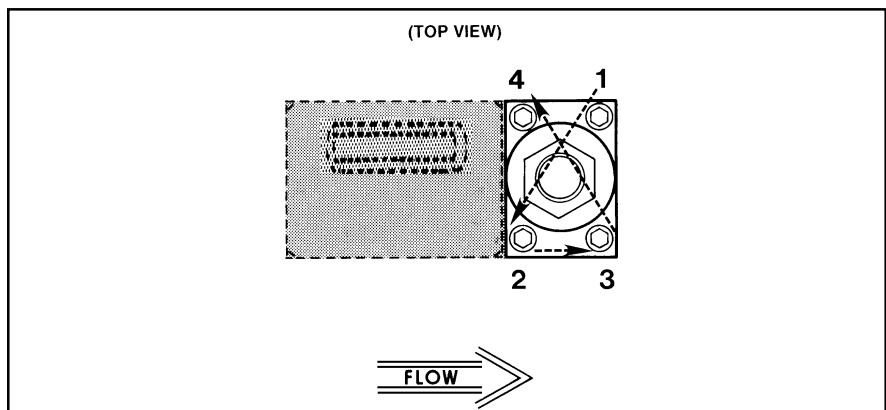

The valve is adjusted in Brooks pressure controllers by adding spacers (9 and 10) to the control valve to vary the initial position of the parts. The proper initial position is required so the valve will have the proper travel and force available to insure reliable control. Screw type adjustments are not used in Brooks control valve since they can change with pressure and vibration. Screw type adjustments also introduce a dynamic seal that is a potential leak site and source for contamination.

The adjustment procedures below require the use of a variable voltage power supply, pressure regulator, pressure gage, voltmeter, flow meter and a supply of nitrogen or air. The test set up is shown in Figure 5-2. The power supply must be capable of delivering 400 mA at 30 V. If the proper equipment or facilities are not available to perform this procedure, please return the instrument to the factory or an authorized repair station. Refer to Figure 7-1 for the location of the parts. Section A describes the adjustment of the Normally Closed control valve, Section B describes the adjustment of the Normally Open control valve. Please refer to the proper section for your valve type.

⚠ CAUTION

When testing upstream type pressure controllers, be certain not to exceed the maximum overpressure specification for the pressure transducer installed, as specified in Section 1-4. For the 0-1 bar transducer this is only 7 psig!

Figure 5-2. Adjustment Test Setup.

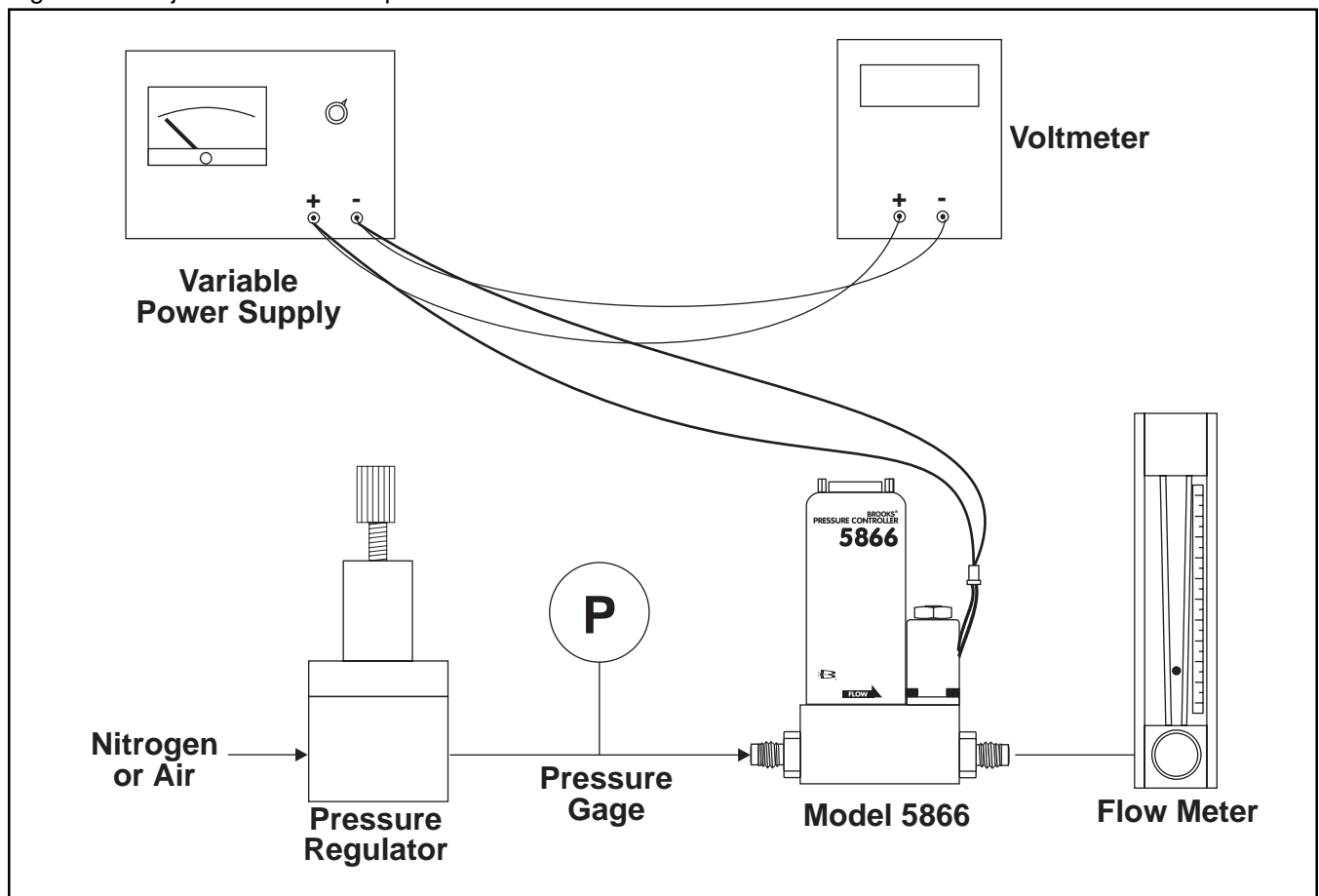

⚠ CAUTION

The procedure described below requires the disassembly of the control valve. Be certain to remove gas pressure prior to disassembly to prevent injury.

A. Adjustment procedure, Normally Closed (N.C.) control valve

Refer to Figure 5-3 for spacer locations and nomenclature for the Normally Closed (N.C.) control valve. Refer to Section 7, spare parts for the spacer part numbers and the spacer kit part number. The preload determines the initial force required to raise the valve seat off the orifice and start gas flow. If the preload is insufficient the valve will not fully close and gas will leak through when the valve is closed. If preload is excessive the magnetic force generated between the plunger and stem will be insufficient to raise the plunger and the valve will not open.

1. Make the bench testing set up as shown in Figure 5-2. Disconnect the valve connector from the side of the Model 5866 and connect it to the variable power supply and voltmeter as shown. Polarity is not important.
2. Remove gas pressure. Disassemble the control valve following the procedure given in Section 5-3, above. Note the orifice size, which is marked on the orifice face. Referring to Figure 5-3, note the number, location and thickness of all spacers (9 and 10).
3. Decrease the preload of the valve by .005" by either removing a .005" small (9) preload spacer or by adding a .005" large (10) preload spacer.
4. Reassemble the control valve following the assembly procedure in Section 5-4, above.
5. Apply 5 psig to the inlet of the Model 5866 if equipped with 0-1 bar transducer. Apply 10 psig for instruments equipped with other transducers.
6. Apply zero Volts to the control valve and observe the flow.
7. If the valve leaks through, remove the gas pressure and increase the preload by .005" and go to Step 8. If the valve does not leak through repeat Steps 2 through 6.
8. Apply 5 psig to the inlet of the Model 5866 if equipped with 0-1 bar transducer. Apply 10 psig for instruments equipped with other transducers.
9. Apply 14.5 Volts to the valve using the variable power supply and observe the flow.
10. Compare the flow with the minimum flow listed in Table 5-3. The minimum flows have been listed with reference to both 0°C and 70°F for convenience. Be sure to use the column that is correct for the flow meter used in the set up. The outlet pressure at the controller must be less than 0.4 psig (10 inches of water).
11. If the observed flow is greater than the flow listed in Table 5-3 go to Step 13.
12. If the observed flow does not achieve the minimum flow, then increase the air gap by adding a large .005" air gap spacer (10) to increase the valve travel. Repeat Steps 8, 9, 10 and 11.
13. Apply 11.5 Volts to the valve using the variable power supply. Observe the flow and compare it to the minimum flow values listed in Table 5-3.
14. If the observed flow is greater than the flow listed in Table 5-3 the valve adjustment is complete.
15. If the observed flow is less than the flow listed in Table 5-3 decrease the air gap by adding a small 0.005" air gap spacer (9). Repeat Steps 13 and 14.

Figure 5-3. Valve Adjusting Spacer Locations.

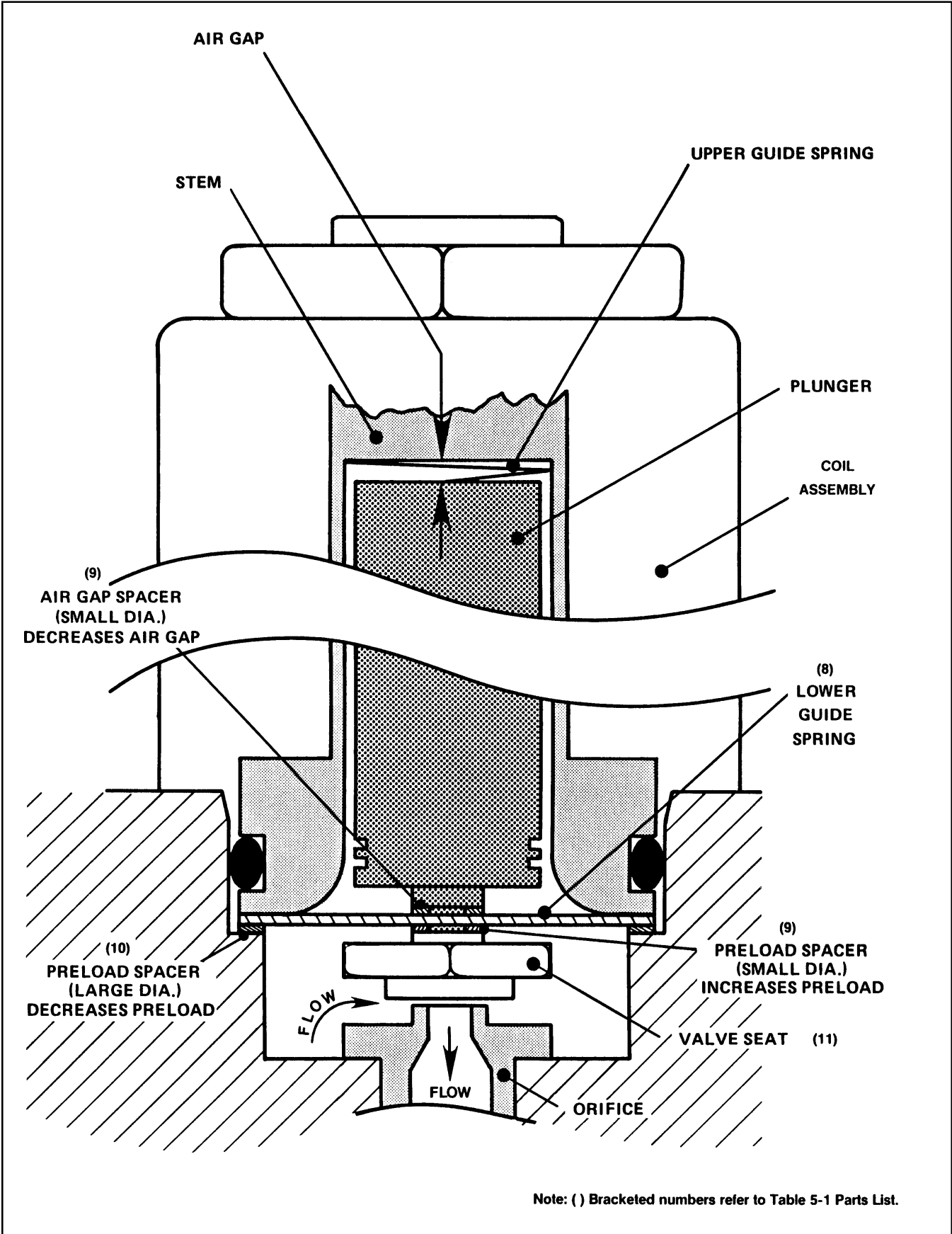

B. Adjustment procedure, Normally Open (N.O.) control valve

Refer to Figure 5-4 for spacer locations and nomenclature for the Normally Open (N.O.) type control valve. Refer to Section 7, spare parts for the spacer part numbers and the spacer kit part number. The valve clearance determines the maximum space between the orifice (12) and the valve seat (11). If the valve clearance is too small the controller will not achieve full flow. If the valve clearance is too large, the control valve will not close properly.

The air gap is the space between the plunger (16) and insert (17) in the control valve. The air gap determines the magnetic force available to operate the valve. If the air gap is too large the magnetic force will be insufficient and the valve will not close. If the air gap is too small the valve will have insufficient travel and the valve will not close.

1. Make the bench testing set up as shown in Figure 5-2. Disconnect the valve connector from the side of the Model 5866 and connect it to the variable power supply and volt meter as shown. Polarity is not important.
2. Remove gas pressure. Disassemble the control valve following the procedure given in Section 5-3, above. Note the orifice size, which is marked on the orifice face. Referring to Figure 5-4, note the number, location and thickness of all spacers (9 and 10).
3. Reassemble the valve and set the variable voltage power supply to zero Volts.
4. Apply 5 psig to the inlet of the Model 5866 if equipped with 0-1 bar transducer. Apply 10 psig for instruments equipped with other transducers.
5. Observe the flow and compare it to the values listed in Table 5-3.
6. If the observed flow is greater than the listed value for the orifice size that is installed then go to Step 8.
7. If the flow is less than the minimum flow increase the valve clearance by adding a large 0.005" spacer (10) above the spring spacer (19) and repeat Steps 5 and 6.
8. Apply 18 Volts to the valve using the variable power supply and observe the flow.

Note: The maximum allowable leak through in controllers with an elastomer valve seat is 2% of the values listed in Table 5-3, (multiply by 0.02). The maximum allowable leak through for controllers with a metal or Teflon valve seat is 8% of the values listed in Table 5-3, (multiply by 0.08).

Table 5-3. Minimum Flow Values.

Orifice Size (inches)	Minimum Flow with 10 psig pressure		Minimum Flow with 5 psig pressure	
	sccm (0°C)	sccm (70°F)	sccm (0°C)	sccm (70°F)
.001	5.3	5.7	3.9	4.0
.002	12.5	13.5	8.8	9.5
.003	39.2	42.2	27.7	29.8
.004	82.5	88.9	58.5	62.9
.007	374	403	264	285
.010	748	806	529	570
.014	1,364	1,470	964	1,039
.020	2,673	2,879	1,890	2,040
.032	6,490	7,000	4,590	4,940
.048	13,000	14,000	9,180	9,890
.062	22,000	23,700	15,500	16,800
.078	31,900	34,400	22,500	24,300
.093	42,500	45,800	30,000	32,400
.120	69,300	74,700	49,000	52,800

Figure 5-4. Valve Adjusting Spacer Locations, Normally Open (N.O.) Valve.

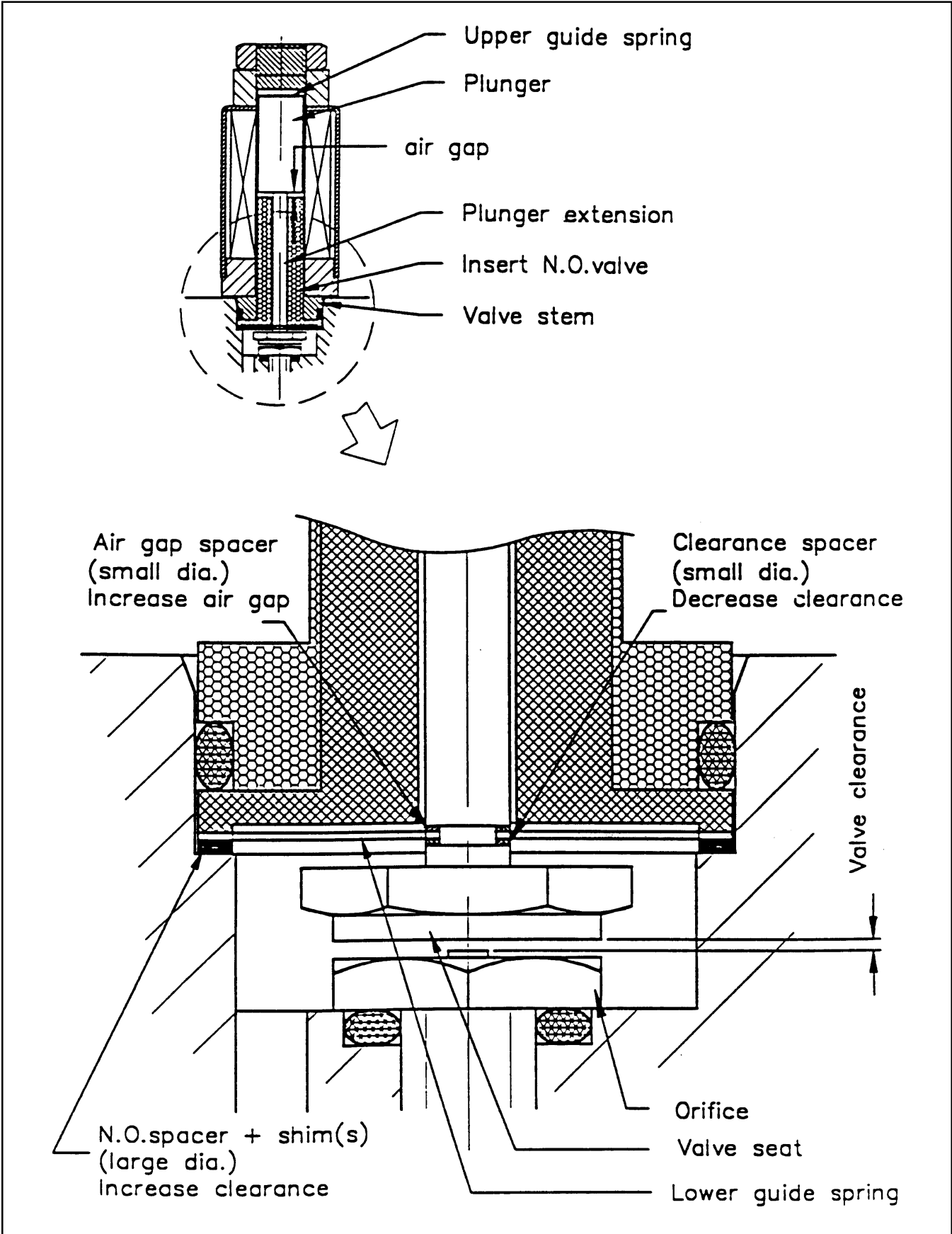

9. If the flow shuts off, or is less than the maximum allowable leak through for the type of valve seat installed the adjustment is complete.
10. If the leakage at 18 Volts is excessive add a large 0.005" spacer (10) to decrease the air gap and repeat Steps 8 and 9.

5-6 Orifice Sizing

The Model 5866 Pressure Controller can be configured with the valve on the outlet to control the pressure upstream of the instrument. This configuration is called an upstream controller. The Model 5866 can also be configured with the valve on the inlet to control the pressure downstream of the instrument. This configuration is called a downstream controller.

The calibration or sensed pressure is the pressure that is controlled. This is the upstream pressure for an upstream controller or downstream pressure for a downstream controller. The reference pressure is the pressure opposite the calibration pressure. The reference pressure would be the downstream pressure for an upstream controller and the upstream pressure for a downstream controller. The reference pressure is usually relatively constant. The calibration pressure is the pressure to which the electronics is calibrated to give 100% output signal. The calibration pressure is the maximum sensed pressure. The above definitions are shown in Figure 5-5.

To properly size the control valve orifice in the Model 5866 the following information must be known:

- Calibration Pressure, psia
 - Reference Pressure, psia
 - T = Gas Temperature (approximate) °R, (°R = °F + 460)
 - Q_{max} = Max. Flow, sccm, 0°C reference temperature
 - SG = Gas Specific Gravity, reference Air @ 14.7 psia and 70°F=1.0
1. Determine the minimum pressure drop across the pressure controller.
 - For an upstream controller this will be when the sensed (inlet) pressure is 5% of the calibration pressure, or 1.5 psi, whichever is larger.
 - For a downstream controller this will be the reference pressure minus the calibration pressure.
 2. Determine the P1 and P2 in psia.
 - For an upstream controller P1 is the reference pressure plus the minimum pressure drop. P2 is the reference pressure.

$$P1 = P_{Ref} + \text{minimum pressure drop}$$

$$P2 = P_{Ref}$$

Figure 5-5. Application Configuration.

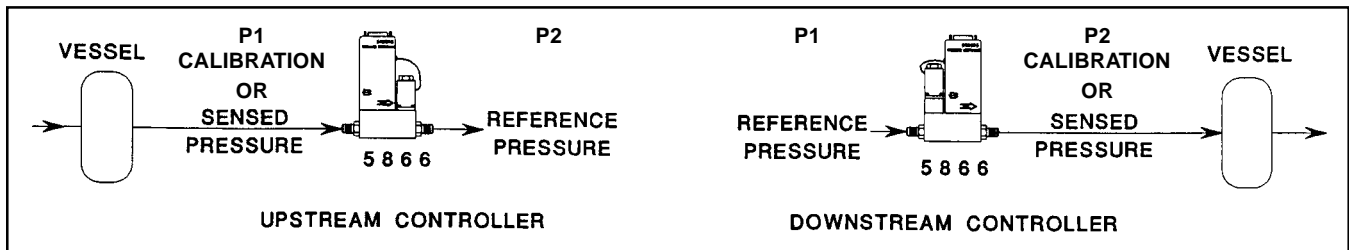

- For a downstream controller P1 is the reference pressure. P2 is the calibration pressure.

$$P1 = P_{Ref}$$

$$P2 = P_{Cal}$$

- Determine the C_v for the application. The ratio between P1 and P2 will determine the calculation to use:

Equation #1

$$\text{If: } \frac{P2}{P1} > 0.5 \text{ use: } C_v = \frac{Q_{max}}{800,000} \sqrt{\frac{SG * T}{(P1 - P2) * P2}}$$

Equation #2

$$\text{If: } \frac{P2}{P1} \leq 0.5 \text{ use: } C_v = \frac{Q_{max}}{397,000 * P1} \sqrt{SG * T}$$

- Select the orifice size from Table 5-4 that has a C_v just greater than the C_v determined in Step 3.
- Check to see if the maximum operating pressure drop is greater than the maximum allowable pressure drop for the orifice size selected. If the pressure drop is too high for the orifice selected the instrument will not be able to function correctly. This situation can be corrected by reducing the pressure drop to the allowable level, or, reducing the maximum flow so a smaller orifice will be selected.

An example Model 5866 application is shown in Figure 5-6 to illustrate the orifice sizing procedure.

Given:

Controller Type: Upstream
 Gas: 5/8 Nitrogen, 3/8 Hydrogen
 Temperature; 70°F (530°R)
 Maximum Flow: 800 sccm
 Calibration Pressure: 100 psig (114.7 psia)
 Reference Pressure; 1 atmosphere (14.7 psia)
 Max Flow: 10 slpm (0°C ref. temp.)

Calculations:

$$SG \text{ Mixture} = (3/8 \times 0.070) + (5/8 \times 0.964) = .629$$

$$\text{Minimum Pressure Drop} = 114.7 \times .05 = 5.7 \text{ psi}$$

$$\text{Maximum Pressure Drop} = 114.7 - 14.7 = 100 \text{ psi}$$

$$P1 = 14.7 + 5.7 = 20.4 \text{ psia}$$

$$P2 = 14.7 \text{ psia}$$

$$P2/P1 = 14.7/20.4 = 0.721 \text{ which is } \geq 0.5 \text{ therefore use equation \#1}$$

$$C_v = \frac{800}{800,000} \sqrt{\frac{0.629 \times 530}{(20.4 - 14.7) \times 14.7}} = 2.0 \times 10^{-3}$$

Since the C_v calculated is the same as listed for the .014" orifice the .020" orifice should be selected. The last step is to check the maximum pressure drop for the application. The maximum pressure drop for the .020 orifice is 300 psi, this is greater than the 100 psi pressure drop required for the application so the .020" orifice is correct.

Table 5-4. Model 5866 Orifice Selection.

C_v	Orifice Size	Maximum Pressure Drop (psi)
5.0×10^{-6}	.001	1500
2.0×10^{-5}	.002	1500
5.0×10^{-5}	.003	1500
1.1×10^{-4}	.004	1500
4.0×10^{-4}	.007	1500
9.0×10^{-4}	.010	750
2.0×10^{-3}	.014	550
4.7×10^{-3}	.020	300
1.4×10^{-2}	.032	175
3.5×10^{-2}	.048	85
5.5×10^{-2}	.062	55
8.0×10^{-2}	.078	50
1.0×10^{-1}	.093	50
1.4×10^{-1}	.116	50
1.5×10^{-1}	.120	50

Figure 5-6. Example Application of Orifice Sizing Procedure.

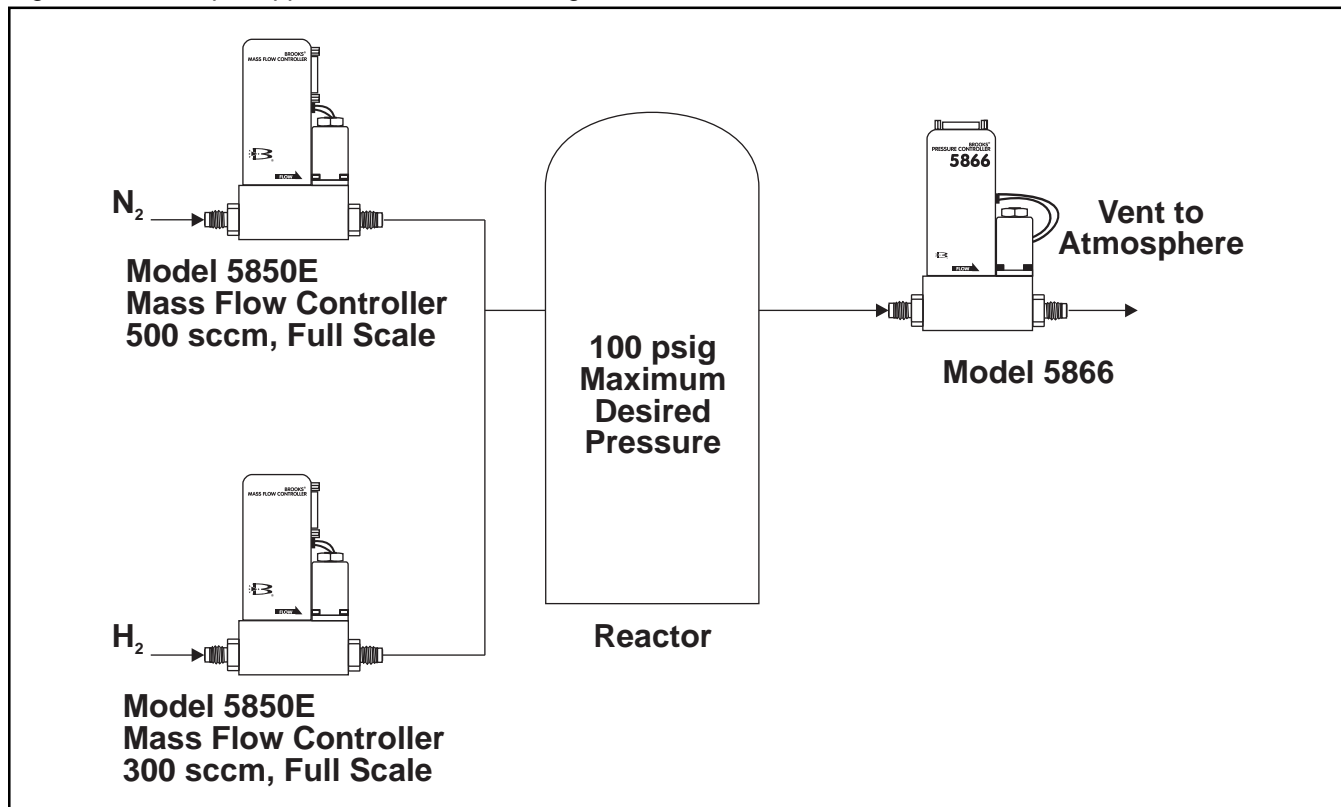

6-1 Calibration Procedure

The calibration of the Model 5866 Pressure Controller can be divided into three parts: Transducer Adjustment, Control Valve Adjustment and Control Electronics Adjustment. The control valve adjustment and sizing procedures are given in Sections 5-5 and 5-6 respectively. The adjustment of the control electronics is best done in the actual system the Model 5866 will be installed in and this procedure is covered in Section 3-2. This section of the manual will cover the calibration of the pressure transducer. Please refer to the above sections of the manual if the control valve or control electronics require adjustment.

Note: Calibration of the Model 5866 Pressure Controller requires the use of a precision pressure and vacuum source, precision pressure indicators and a digital voltmeter (DVM). The calibration may also involve high pressure. It is recommended the calibration procedure be performed by qualified personnel.

⚠ CAUTION

Excessive pressure can damage the pressure transducer and make it inoperative. Care must be taken not to allow the pressure transducer to be exposed to more than the maximum over-range pressure. The maximum over-range pressure is specific to the range of the pressure transducer. These pressures are listed in Section 1-4 of this manual.

Refer to Figures 1-9 and 1-10 for locations for the adjustment potentiometers, jumpers and D-Connector pins.

1. Connect power to the instrument and allow it to warm up for approximately 15 minutes.
2. Connect the DVM positive lead to the +5 Volt reference output (Pin 11) and the DVM negative lead to signal ground (Pin 10). Adjust the +5 Volt reference output to 5.000 V using P1.
3. Connect the DVM positive lead to the pressure signal output (Pin 2) and the negative lead to signal ground (Pin 10). Connect the transducer side of the Model 5866 to a vacuum source capable of achieving an absolute pressure less than 0.02 psia (1 Torr). Put a cap or some suitable plug on valve side inlet. Attaching the transducer side of the Model 5866 to a mass spectrometer type helium leak detector is a good way to achieve a suitable vacuum. Adjust the signal output to 0.000 V using zero potentiometer, P4.

Note: If a vacuum pump is not available and the atmospheric pressure is accurately known the zero pressure signal output can be adjusted using the following formula:

$$\text{Output at Atmospheric Pressure (Vdc)} = \frac{\text{Output at 100\% (Vdc)}}{\text{Pressure at 100\% (psia)}} \times \text{Atmospheric Pressure (psia)}$$

The above formula will be most accurate with high pressure transducers where the output at atmospheric pressure is a small fraction of the full scale pressure.

4. Apply the desired full scale pressure to the transducer side of the Model 5866 and adjust the span potentiometer (P3) so the Model 5866 output agrees with the output of the precision pressure indicator. If the output cannot be adjusted to the correct value with the span potentiometer change the course gain setting by moving jumper (J1).
5. Apply a vacuum to the transducer side of the Model 5866 and check zero pressure output. If the zero pressure output is correct, the calibration is complete. If zero pressure output is not correct, repeat Steps 3 and 4. Readjustment will probably only be required if the atmospheric pressure method of adjustment was used to set zero.

6-2 Gas Conversion Factors

If a mass flow controller is operated on a gas other than the gas it was calibrated with, a scale shift will occur in the relation between the output signal and the mass flow rate. This is due to the difference in heat capacities between the two gases. This scale shift can be approximated by using the ratio of the molar specific heat of the two gases or by sensor conversion factor. A list of sensor conversion factors is given in Table 6-1. To change to a new gas, multiply the output reading by the ratio of the gas factor for the desired gas by the gas factor for the calibration gas used.

$$\text{Actual Gas Flow Rate} = \text{Output Reading} \times \frac{\text{Factor of the New Gas}}{\text{Factor of the Calibration Gas}}$$

Example:

The controller is calibrated for Nitrogen.

The desired gas is Carbon Dioxide

The output reading is 75 sccm when Carbon Dioxide is flowing

Then $75 \times 0.773 = 57.98$ sccm

In order to calculate the conversion factor for a gas mixture, the following formula should be used:

$$\text{Sensor Conversion Factor}_{\text{Mixture}} = \frac{100}{\frac{P_1}{\text{Sensor Conversion Factor}_1} + \frac{P_2}{\text{Sensor Conversion Factor}_2} + \frac{P_3}{\text{Sensor Conversion Factor}_3}}$$

Where,

P_1 = percentage (%) of gas 1 (by volume)

P_2 = percentage (%) of gas 2 (by volume)

P_n = percentage (%) of gas n (by volume)

Example: The desired gas is 20% Helium (He) and 80% Chlorine (Cl) by volume. The desired full scale flow rate of the mixture is 20 slpm. Sensor conversion factor for the mixture is:

$$\text{Mixture Factor} = \frac{100}{\frac{20}{1.386} + \frac{80}{0.876}} = 0.945$$

Nitrogen equivalent flow = $20 / 0.945 = 21.16$ slpm Nitrogen

It is generally accepted that the mass flow rate derived from this equation is only accurate to $\pm 5\%$. The sensor conversion factors given in Table 6-1 are calculated based on a gas temperature of 21°C and a pressure of one atmosphere. The specific heat of most gases is not strongly pressure, and/or temperature, dependent. However, gas conditions that vary widely from these reference conditions may cause an additional error due to the change in specific heat caused by pressure and/or temperature.

Brooks Instrument Model 5866 Pressure Controller

Table 6-1. Conversion Factors (Nitrogen Base).

GAS NAME	FORMULA	SENSOR FACTOR	ORIFICE FACTOR	DENSITY (kg/m ³)
Acetylene	C ₂ H ₂	0.615	0.970	1.173
Air	Mixture	0.998	1.018	1.293
Allene	C ₃ H ₄	0.478	1.199	1.787
Ammonia	NH ₃	0.786	0.781	0.771
Argon	Ar	1.395	1.195	1.784
Arsine	AsH ₃	0.754	1.661	3.478
Boron Trichloride	BCL ₃	0.443	2.044	5.227
Boron Trifluoride	BF ₃	0.579	1.569	3.025
Bromine Pentafluoride	BrF ₅	0.287	2.502	7.806
Bromine Trifluoride	BrF ₃	0.439	2.214	6.108
Bromotrifluoroethylene	C ₂ BrF ₃	0.326	2.397	7.165
Bromotrifluoromethane f-13B1	CBrF ₃	0.412	2.303	6.615
1,3-Butadiene	C ₄ H ₆	0.354	1.413	2.491
Butane	C ₄ H ₁₀	0.257	1.467	2.593
1-Butene	C ₄ H ₈	0.294	1.435	2.503
CIS-2-Butene	C ₄ H ₈	0.320	1.435	2.503
Trans-2-Butene	C ₄ H ₈	0.291	1.435	2.503
Carbon Dioxide	CO ₂	0.773	1.255	1.977
Carbon Disulfide	CS ₂	0.638	1.650	3.393
Carbon Monoxide	CO	0.995	1.000	1.250
Carbon Tetrachloride	CCL ₄	0.344	2.345	6.860
Carbon Tetrafluoride f-14	CF ₄	0.440	1.770	3.926
Carbonyl Fluoride	COF ₂	0.567	1.555	2.045
Carbonyl Sulfide	COS	0.680	1.463	2.180
Chlorine	Cl ₂	0.876	1.598	3.214
Chlorine Dioxide	ClO ₂	0.693	1.554	3.011
Chlorine Trifluoride	ClF ₃	0.433	1.812	4.125
2-Chlorobutane	C ₄ H ₉ Cl	0.234	1.818	4.134
Chlorodifluoromethane f-22	CHClF ₂	0.505	1.770	3.906
Chloroform (Trichloromethane)	CHCl ₃	0.442	2.066	5.340
Chloropentafluoroethane f-115	C ₂ ClF ₅	0.243	2.397	7.165
Chlorotrifluoroethylene	C ₂ ClF ₃	0.337	2.044	5.208
Chlorotrifluoromethane f-13	CClF ₃	0.430	1.985	4.912
Cyanogen	(CN) ₂	0.498	1.366	2.322
Cyanogen Chloride	LCN	0.618	1.480	2.730
Cyclobutane	C ₄ H ₈	0.387	1.413	2.491
Cyclopropane	C ₃ H ₆	0.505	1.224	1.877
Deuterium	D ₂	0.995	0.379	0.177
Diborane	B ₂ H ₆	0.448	1.000	1.235
Dibromodifluoromethane f-12B2	CBr ₂ F ₂	0.363	2.652	8.768
1,2-Dibromotetrafluoroethane f-114B2	C ₂ Br ₂ F ₄	0.215	2.905	10.53
Dichlorodifluoromethane f-12	CCl ₂ F ₂	0.390	2.099	5.492
Dichlorofluoromethane f-21	CHCl ₂ F	0.456	1.985	4.912
Dichlorosilane	SiH ₂ Cl ₂	0.442	1.897	4.506
1,2-Dichloroethane	C ₂ H ₄ Cl ₂	0.382	1.879	4.419
1,2-Dichlorotetrafluoroethane f-114	C ₂ Cl ₂ F ₄	0.231	2.449	7.479
2,2 Dichloro	C ₂ HC ₁₂ F ₃	0.259	2.336	6.829
1,1-Difluoro-1-Chloroethane	C ₂ H ₃ ClF ₂	0.341	1.957	4.776
1,1-Difluoroethane	CH ₃ CHF ₂	0.415	1.536	2.940
1,1-Difluoroethylene	CH ₂ :CF ₂	0.458	1.512	2.860
Diethylsilane	C ₂ H ₁₂ Si	0.183	1.775	3.940
Difluoromethane f-32	CF ₂ H ₂	0.627	1.360	2.411
Dimethylamine	(CH ₃) ₂ NH	0.370	1.269	2.013
Dimethylether	(CH ₃) ₂ O	0.392	1.281	2.055
2,2-Dimethylpropane	C(CH ₃) ₄	0.247	1.613	3.244
Disilane	Si ₂ H ₆	0.332	1.493	2.779
Ethane	C ₂ H ₆	0.490	1.038	1.357
Ethanol	C ₂ H ₆ O	0.394	1.282	2.057
Ethylacetylene	C ₄ H ₆	0.365	1.384	2.388
Ethyl Chloride	C ₂ H ₅ Cl	0.408	1.516	2.879
Ethylene	C ₂ H ₄	0.619	1.000	1.261
Ethylene Oxide	C ₂ H ₄ O	0.589	1.254	1.965
Fluorine	F ₂	0.924	1.163	1.695
Fluoroform f-23	CHF ₃	0.529	1.584	3.127
Germane	GeH ₄	0.649	1.653	3.418
Germanium Tetrachloride	GeCl ₄	0.268	2.766	9.574
Halothane (R-123B1)	C ₂ HBrClF ₃	0.257	2.654	8.814
Helium	He	1.386	0.378	0.178
Hexafluoroacetone	F ₃ CCOCF ₃	0.219	2.434	7.414
Hexafluorobenzene	C ₆ F ₆	0.632	2.577	8.309
Hexafluoroethane f-116	C ₂ F ₆	0.255	2.219	6.139
Hexafluoropropylene (HFP)	C ₃ F ₆	0.249	2.312	6.663
Hexamethyldisilane (HMDS)	(CH ₃) ₆ Si ₂	0.139	2.404	7.208
Hexane	C ₆ H ₁₄	0.204	1.757	3.847

Ref. No. J-836D508
gasdata.doc Vsn. 8.6

Table 6-1. Conversion Factors (Nitrogen Base) Continued.

GAS NAME	FORMULA	SENSOR FACTOR	ORIFICE FACTOR	DENSITY (kg/m ³)
Hydrogen	H ₂	1.008	0.269	0.090
Hydrogen Bromide	HBr	0.987	1.695	3.645
Hydrogen Chloride	HCL	0.983	1.141	1.639
Hydrogen Cyanide	HCN	0.744	0.973	1.179
Hydrogen Fluoride	HF	0.998	0.845	0.893
Hydrogen Iodide	HI	0.953	2.144	5.789
Hydrogen Selenide	H ₂ Se	0.837	1.695	3.613
Hydrogen Sulfide	H ₂ S	0.850	1.108	1.539
Iodine Pentafluoride	IF ₅	0.283	2.819	9.907
Isobutane	C ₄ H ₁₀	0.260	1.440	2.593
Isobutene	C ₄ H ₈	0.289	1.435	2.503
Isopentane	C ₅ H ₁₂	0.211	1.605	3.222
Krypton	Kr	1.382	1.729	3.708
Methane	CH ₄	0.763	0.763	0.717
Methylacetylene	C ₃ H ₄	0.473	1.196	1.782
Methyl Bromide	CH ₃ Br	0.646	1.834	4.236
3-Methyl-1-butene	C ₅ H ₁₀	0.252	1.584	3.127
Methyl Chloride	CH ₃ CL	0.687	1.347	2.308
Methyl Fluoride	CH ₃ F	0.761	1.102	1.518
Methyl Mercaptan	CH ₃ S	0.588	1.313	2.146
Methyl Silane	CH ₃ Si	0.393	1.283	2.061
Methyl Trichlorosilane (MTS)	CH ₃ Cl ₃ Si	0.267	2.310	6.675
Methyl Vinyl Ether	C ₃ H ₆ O	0.377	1.435	2.567
Monoethanolamine	C ₂ H ₇ NO	0.305	1.477	2.728
Monoethylamine	C ₂ HH ₅ NH ₂	0.359	1.269	2.013
Monomethylamine	CH ₃ NH ₂	0.565	1.067	1.420
Neon	Ne	1.398	0.847	0.902
Nickel Carbonyl	Ni(CO) ₄	0.212	2.371	7.008
Nitric Oxide	NO	0.995	1.030	1.339
Nitrogen	N ₂	1.000	1.000	1.251
Nitrogen Dioxide	NO ₂	0.758	1.713	2.052
Nitrogen Trifluoride	NF ₃	0.501	1.598	3.168
Nitrogen Trioxide	N ₂ O ₃	0.443	1.649	3.389
Nitrosyl Chloride	NOCL	0.644	1.529	2.913
Nitrous Oxide	N ₂ O	0.752	1.259	1.964
Octofluorocyclobutane	C ₄ F ₈	0.169	2.672	8.933
Oxygen	O ₂	0.988	1.067	1.429
Oxygen Difluoride	OF ₂	0.672	1.388	2.402
Ozone	O ₃	0.738	1.310	2.138
Pentafluoroethane f-125	C ₂ HF ₅	0.287	2.070	5.360
Pentane (n-Pentane)	C ₅ H ₁₂	0.212	1.605	3.222
Perchloryl Fluoride	ClO ₂ F	0.448	1.905	4.571
Perfluorobutane	C ₄ F ₁₀	0.738	2.918	10.61
Perfluoro-2-Butene	C ₄ F ₈	0.268	2.672	8.933
Perfluoromethyl-vinylether	PMVE	0.296	2.029	5.131
Perfluoropropane	C ₃ F ₈	0.179	2.591	8.396
Pentane (n-Pentane)	C ₅ H ₁₂	0.212	1.605	3.222
Phosgene	COCL ₂	0.504	1.881	4.418
Phosphine	PH ₃	0.783	1.100	1.517
Phosphorous Pentafluoride	PF ₅	0.346	2.109	5.620
Phosphorous Trifluoride	PF ₃	0.495	1.770	3.906
Propane (same as CH ₃ CH ₂ CH ₃)	C ₃ H ₈	0.343	1.274	2.008
Propylene (Propene)	C ₃ H ₆	0.401	1.234	1.875
Rhenium Hexafluoride	ReF ₆	0.230	3.279	13.41
Silane	SiH ₄	0.625	1.070	1.440
Silicon Tetrachloride	SiCL ₄	0.310	2.465	7.579
Silicon Tetrafluoride	SiF ₄	0.395	1.931	4.648
Sulfur Dioxide	SO ₂	0.728	1.529	2.858
Sulfur Hexafluoride	SF ₆	0.270	2.348	6.516
Sulfur Tetrafluoride	SF ₄	0.353	1.957	4.776
Sulfur Trioxide	SO ₃	0.535	1.691	3.575
Sulfuryl Fluoride	SO ₂ F ₂	0.423	1.931	4.648
Tetrachloromethane	CCL ₄	0.344	2.345	6.858
Tetrafluoroethylene (TFE)	C ₂ F ₄	0.361	1.905	4.526
Tetrafluorohydrazine	N ₂ F ₄	0.367	1.926	4.624
Trichlorofluoromethane f-11	CCL ₃ F	0.374	2.244	6.281
Trichlorosilane	SiHCl ₃	0.329	2.201	6.038
Trimethoxyborane (TMB)	B(OCH ₃) ₃	0.300	1.929	4.638
1,1,2-Trichloro-1,1,2-Trifluoroet f-113	C ₂ CL ₃ F ₃	0.231	2.520	7.920
Trimethylamine	(CH ₃) ₃ N	0.316	1.467	2.639
Tungsten Hexafluoride	WF ₆	0.227	3.264	13.28
Uranium Hexafluoride	UF ₆	0.220	3.548	15.70
Vinyl Bromide	C ₂ H ₃ Br	0.524	1.985	4.772
Vinyl Chloride	C ₂ H ₃ CL	0.542	1.492	2.788
Vinyl Fluoride	C ₂ H ₃ F	0.576	1.281	2.046
Water Vapor	H ₂ O	0.861	0.802	0.804
Xenon	Xe	1.383	2.180	5.851

7-1 General

Replacement parts for the Model 5866 are readily available worldwide through the factories and customer service facilities listed on the back cover of this manual. Parts can also be ordered through authorized repair stations and sales agents. When ordering replacement parts please specify: Brooks serial number, model number, part description, part number and quantity.

Refer to Figure 7-1 and Table 7-1 for Model 5866E parts drawing and list and Figure 7-2 and Table 7-3 for Model 5866M parts drawing and list. Table 7-2 lists tools and parts that are useful for troubleshooting and repair.

Figure 7-1. Model 5866E Parts Drawing.

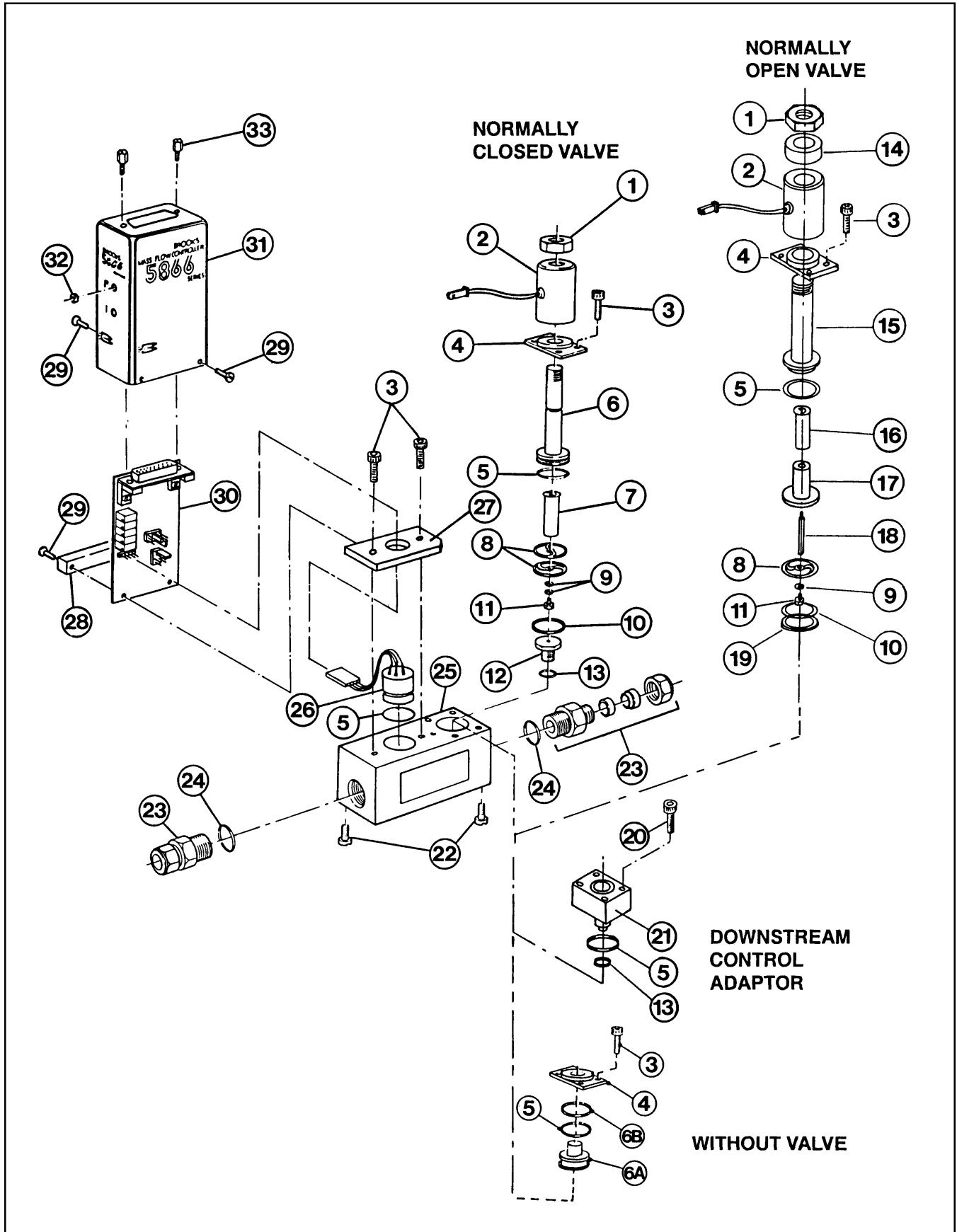

Figure 7-2. Model 5866M Parts Drawing.

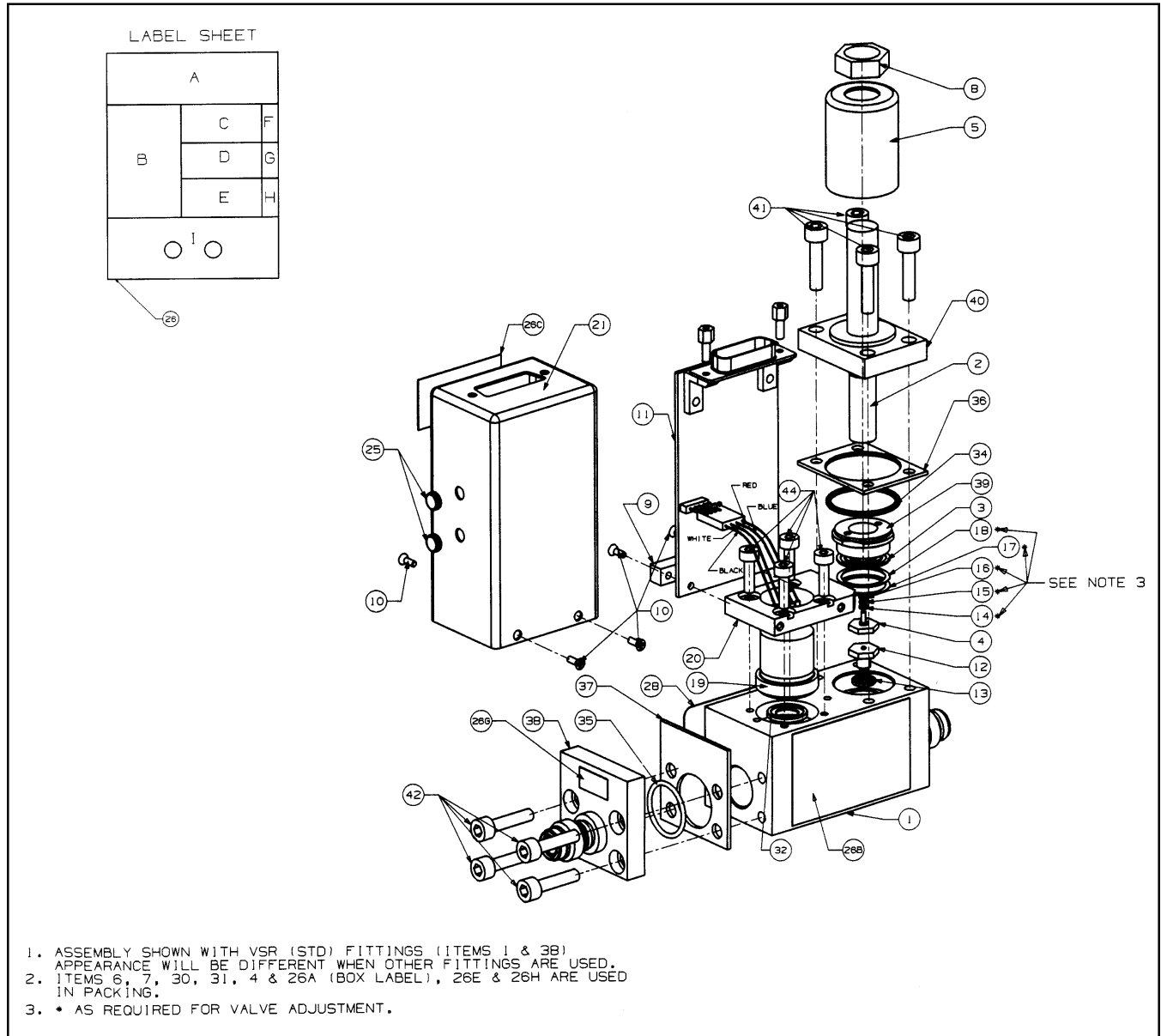

Table 7-3. Model 5866M Parts List.

SEQ.#	COMPONENT #	DESCRIPTION	QTY
1	S092Z924BIT	BODY WELDMENT MOD 5866M	1
2	S622Z181QOG	EP PLUNGER W/UGS NORM CL	1
3	820Z110DR%	LOWER GUIDE SPRING .020	1
4	S715Z051AAG	3/8 VITON MOLDED SEAT-EP	1
5	S185Z280AAJ	COIL ASSY-METAL SEAL MF	1
6	315Z047AAA	END CAP 1/4" MALE VCR FT	2
7	715Z296AAA	GASKET, RETAINER 1/4" VCR	2
8	573B027ACJ	NUT FINISHED JAM 7/16-20	1
9	079Z135EAA	CAN MTG BRACKET BLOCK 58	1
10	753L056AWZ	SCR MCH PHIL FLAT HD 2-5	5
11	097B190ZZZ	PC BOARD ASSY 5866 BV PU	1
12	577Z391BM\$.032 ORIFICE 3/8 HEX-FP	1
13	577Z488AA\$	METAL SEAL ORIFICE POL	1
14	810A374BMA	SPACER .002" THK 1/8" OD	1
15	810A362BMA	SPACER .005" THK 1/8" OD	1
16	810A363BMA	SPACER .010" THK 1/8" OD	1
17	810A368BMA	SPACER .005" THK .748" OD	1
18	810A361BMA	LWR SPACER .010" THK .748	1
19	S019Z310AAA	ADAPTER & SENSOR ASSY 58	1
20	613Z582BMT	BASE PLATE MOD 5866M	1
21	219Z553EAJ	COVER SILKSCREENED MOD 5	1
25	620Z434SXA	PLUG POT HOLE	2
32	763Z070AAA	#2-013 "H" SEAL, 5866EM	1
34	375F098BMJ	METAL O'RING 1.039 OD X	1
35	375F099BMJ	METAL O'RING .757 OD X	1
36	810Z191BMT	VALVE PLATE SPACER 5850E	1
37	810Z190BMT	INLET SPACER 5850EM	1
38	S320Z087BIT	STD VCR INLET BLOCK, NON	1
39	573Z264BMG	GLAND NUT-N.C. VLV 5964	1
40	949Z213QOT	N.C. VALVE STEM 5850EM	1
41	751Z111AAA	SOCKET HD 10-32X3/4 UNRF	4
42	751Z103AAO	SOC HD CAP SCREW 10-32 UN	4
44	751Z107AAO	6-32 X 1/2 SOCKET HD CAP	4

Bulgarian

Brooks Instrument
Neonstraat 3
6718 WX Ede
The Netherlands

Български

Всички снабдени с означението CE оборудвания Brooks (електрически/електронни) са преминали успешно през тестове съответно изискванията на електромагнитната съвместимост. (предписание на EMC 89/336/ЕЕС).

Обаче на избирането на сигнални кабели за снабдените с означението CE оборудвания, трябва да се обръща особено внимание.

Качество на сигналните кабели, кабелните салници и присъединителните елементи:

Brooks осигурява кабелна инсталация с отлично качество, която отговаря на изискванията на директивите на CE.

Ако обаче искате да използвате свой сигнален кабел, изберете сигнален кабел с поне 100%-во покритие, който е напълно екраниран.

Който и да е използван „D” или коаксиален присъединителен елемент, трябва да бъде екраниран с метална броня. Ако е приложимо, покритието на кабелите трябва да се стегне с метални кабелни салници. Покритието на кабелите трябва да се присъедини към металното защитно покритие или салника, и и на двата си края трябва да осигурява 360⁰-во екраниране.

Покритието трябва да се свърже към една заземяваща клема.

Напечатаните на платката присъединителни елементи са неметални, по стандарт. Използваните кабели, за да отговарят на директивите на CE, трябва да имат 100 % -во екраниране.

Czech

Brooks Instrument
Neonstraat 3
6718 WX Ede
The Netherlands

Český jazyk

Všechny (elektrické/elektronické) přístroje Brooks, které jsou označeny značkou CE, byly úspěšně testovány na elektromagnetickou kompatibilitu (předpis EMC 89/336/ЕЕС).

Při výběru signalizačních kabelů, které chcete u přístrojů se značkou CE použít je třeba věnovat zvýšenou pozornost.

Kvalita signalizačních kabelů, kabelových průchodků a přípojovacích svorek:

Brooks zabezpečuje spolehlivou kabeláž, která vyhovuje požadavkům směrnic CE. Chcete-li použít vlastní signalizační kabel, volte kabel s krytím nejméně 100 %, s úplným stíněním.

Jakákoliv použitá koaxiální přípojovací svorka nebo „D” svorka musí být stíněná kovovým pláštěm. Je-li to řešitelné, krytí kabelů je nutné zabezpečit kovovou kabelovou průchodkou. Stínění kabelu je třeba propojit s kovovým ochranným krytem nebo kovovou kabelovou průchodkou a na obou dvou koncích kabelu musí být zajištěno stínění 360⁰.

Kovový kryt se musí propojit s uzemňovací svorkou.

Přípojovací svorky, nalisované na kartu nejsou kovové, jako je ve standardech, stínění použitých kabelů musí být minimálně 100 %, aby vyhověly CE směrnicím.

Dansk

Brooks Instrument
Neonstraat 3
6718 WX Ede
The Netherlands

Emne : Tillæg til instruktions manual.

Reference : CE mærkning af Masse Flow udstyr

Dato : Januar-1996.

Brooks Instrument har gennemført CE mærkning af elektronisk udstyr med succes, i henhold til regulativet om elektrisk støj (EMC direktivet 89/336/EEC).

Der skal dog gøres opmærksom på benyttelsen af signalkabler i forbindelse med CE mærkede udstyr.

Kvaliteten af signal kabler og stik:

Brooks lever kabler af høj kvalitet, der imødekommer specifikationerne til CE mærkning.

Hvis der anvendes andre kabel typer skal der benyttes et skærmet kabel med hel skærm med 100% dækning.

Forbindelses stikket type "D" eller "cirkulære", skal være skærmet med metalhus og eventuelle PG-forskrninger skal enten være af metal eller metal skærmet.

Skærmen skal forbindes, i begge ender, til stikkets metalhus eller PG-forskrningen og have forbindelse over 360 grader. Skærmen bør være forbundet til jord.

"Card Edge" stik er standard ikke af metal, der skal derfor ligeledes benyttes et skærmet kabel med hel skærm med 100% dækning.

Skærmen bør være forbundet til jord.

Forbindelse af stikket; venligst referer til vedlagte instruktions manual.

Med venlig hilsen,

Deutsch

Brooks Instrument
Neonstraat 3
6718 WX Ede
The Netherlands

Subjekt : Nachtrag zur Bedienungsanleitung.

Referenz: CE Zertifizierung für Massedurchflußgeräte

Datum : Januar-1996.

Nach erfolgreichen Tests entsprechend den Vorschriften der Elektromagnetischen Verträglichkeit (EMC Richtlinie 89/336/EEC) erhalten die Brooks-Geräte (elektrische/elektronische Komponenten) das CE-Zeichen.

Bei der Auswahl der Verbindungskabel für CE-zertifizierte Geräte sind spezielle Anforderungen zu beachten.

Qualität der Verbindungskabel, Anschlußstecker und der Kabeldurchführungen

Die hochwertigen Qualitätskabel von Brooks entsprechen der Spezifikation der CE-Zertifizierung.

Bei Verwendung eigener Verbindungskabel sollten Sie darauf achten, daß eine

100 %igen Schirmabdeckung des Kabels gewährleistet ist.

"D" oder "Rund" -Verbindungsstecker sollten eine Abschirmung aus Metall besitzen.

Wenn möglich, sollten Kabeldurchführungen mit Anschlußmöglichkeiten für die Kabelabschirmung verwendet werden.

Die Abschirmung des Kabels ist auf beiden Seiten des Steckers oder der Kabeldurchführungen über den vollen Umfang von 360 ° anzuschließen.

Die Abschirmung ist mit dem Erdpotential zu verbinden.

Platinen-Steckverbindungen sind standardmäßige keine metallgeschirmten Verbindungen. Um die Anforderungen der CE-Zertifizierung zu erfüllen, sind Kabel mit einer 100 %igen Schirmabdeckung zu verwenden.

Die Abschirmung ist mit dem Erdpotential zu verbinden.

Die Belegung der Anschlußpins können Sie dem beigelegten Bedienungshandbuch entnehmen.

English

Brooks Instrument

Neonstraat 3

6718 WX Ede

The Netherlands

Subject : Addendum to the Instruction Manual.

Reference : CE certification of Mass Flow Equipment

Date : January-1996.

The Brooks (electric/electronic) equipment bearing the CE mark has been successfully tested to the regulations of the Electro Magnetic Compatibility (EMC directive 89/336/EEC).

Special attention however is required when selecting the signal cable to be used with CE marked equipment.

Quality of the signal cable, cable glands and connectors:

Brooks supplies high quality cable(s) which meets the specifications for CE certification.

If you provide your own signal cable you should use a cable which is overall completely screened with a 100% shield.

"D" or "Circular" type connectors used should be shielded with a metal shield. If applicable, metal cable glands must be used providing cable screen clamping.

The cable screen should be connected to the metal shell or gland and shielded at both ends over 360 Degrees.

The shield should be terminated to a earth ground.

Card Edge Connectors are standard non-metallic. The cables used must be screened with 100% shield to comply with CE certification.

The shield should be terminated to a earth ground.

For pin configuration : Please refer to the enclosed Instruction Manual.

Eesti

Brooks Instrument

Neonstraat 3

6718 WX Ede

The Netherlands

Brooksi kogu CE-märki kandev (elektriline ja elektrooniline) seadmestik on edukalt läbinud katsed vastavalt elektromagnetilise ühilduvuse eeskirjadele (elektromagnetilise ühilduvuse direktiiv 89/336/EMÜ). Signaalkaablite valimisel kasutamiseks koos CE-vastavusmärgi omavate seadmetega tuleb siiski järgida spetsiaalseid nõudeid.

Signaalkaablite, läbiviikihendite ja pistikühenduste kvaliteet:

Brooks valmistab kvaliteetkaableid, mis vastavad CE-sertifitseerimise spetsifikatsioonidele.

Kui te aga soovite kasutada oma signaalkaablit, peaksite valima täielikult varjestatud kaabli vähemalt 100% varjestusega.

Kasutatavad poolümar- või ümarühendused tuleb varjestada metallekraaniga. Võimaluse korral tuleb kaablivarje kinnitamiseks kasutada metallist kaablihooldikuid.

Kaabli kraan tuleb ühendada metallkesta või -tihendiga ning varustada mõlemas otsas varjestusega 360° ulatuses. Varjestus tuleb ühendada maandusklemmiga.

Plaadi külghendused on tavaliselt mittemetalsest materjalist. CE-sertifitseerimisnõuetele vastamiseks peavad kasutatavad kaablid olema varustatud 100% varjestusega.

Español

Brooks Instrument
Neonstraat 3
6718 WX Ede
The Netherlands

Asunto : Addendum al Manual de Instrucciones.

Referencia : Certificación CE de los Equipos de Caudal Másico

Fecha : Enero-1996.

Los equipos de Brooks (eléctricos/electrónicos) en relación con la marca CE han pasado satisfactoriamente las pruebas referentes a las regulaciones de Compatibilidad Electro magnética (EMC directiva 89/336/EEC).

Sin embargo se requiere una atención especial en el momento de seleccionar el cable de señal cuando se va a utilizar un equipo con marca CE

Calidad del cable de señal, prensaestopas y conectores:

Brooks suministra cable(s) de alta calidad, que cumple las especificaciones de la certificación CE .

Si usted adquiere su propio cable de señal, debería usar un cable que esté completamente protegido en su conjunto con un apantallamiento del 100%.

Cuando utilice conectores del tipo "D" ó "Circular" deberían estar protegidos con una pantalla metálica. Cuando sea posible, se deberán utilizar prensaestopas metálicos provistos de abrazadera para la pantalla del cable.

La pantalla del cable deberá ser conectada al casquillo metálico ó prensa y protegida en ambos extremos completamente en los 360 Grados.

La pantalla deberá conectarse a tierra.

Los conectores estandar de tipo tarjeta (Card Edge) no son metálicos, los cables utilizados deberán ser protegidos con un apantallamiento del 100% para cumplir con la certificación CE.

La pantalla deberá conectarse a tierra.

Para ver la configuración de los pines: Por favor, consultar Manual de Instrucciones adjunto.

Français

Brooks Instrument
Neonstraat 3
6718 WX Ede
The Netherlands

Sujet : Annexe au Manuel d'Instructions.

Référence : Certification CE des Débitmètres Massiques à Effet Thermique.

Date : Janvier 1996.

Messieurs,

Les équipements Brooks (électriques/électroniques) portant le label CE ont été testés avec succès selon les règles de la Compatibilité Electromagnétique (directive CEM 89/336/EEC).

Cependant, la plus grande attention doit être apportée en ce qui concerne la sélection du câble utilisé pour véhiculer le signal d'un appareil portant le label CE.

Qualité du câble, des presse-étoupes et des connecteurs:

Brooks fournit des câbles de haute qualité répondant aux spécifications de la certification CE.

Si vous approvisionnez vous-même ce câble, vous devez utiliser un câble blindé à 100 %.

Les connecteurs « D » ou de type « circulaire » doivent être reliés à la terre.

Si des presse-étoupes sont nécessaires, ceux ci doivent être métalliques avec mise à la terre.

Le blindage doit être raccordé aux connecteurs métalliques ou aux presse-étoupes sur le pourtour complet du câble, et à chacune de ses extrémités.

Tous les blindages doivent être reliés à la terre.

Les connecteurs de type « card edge » sont non métalliques. Les câbles utilisés doivent être blindés à 100% pour satisfaire à la réglementation CE.

Tous les blindages doivent être reliés à la terre.

Se référer au manuel d'instruction pour le raccordement des contacts.

Greek

Brooks Instrument

Neonstraat 3

6718 WX Ede

The Netherlands

Θέμα : Προσθήκη στο Εγχειρίδιο Οδηγιών.
Σχετικά : Πιστοποίηση CE των Οργάνων Μέτρησης Παροχής Μάζας.
Ημερομηνία : Ιανουάριος - 1996

Κυρίες και Κύριοι,

Τα όργανα (ηλεκτρικά/ηλεκτρονικά) της Brooks τα οποία φέρουν το σήμα CE έχουν επιτυχώς ελεγχθεί σύμφωνα με τους κανονισμούς της Ηλεκτρο-Μαγνητικής Συμβατότητας (EMC ντιρεκτίβα 89/336/EEC).

Οπωσδήποτε χρειάζεται ειδική προσοχή κατά την επιλογή του καλωδίου μεταφοράς του σήματος το οποίο (καλώδιο) πρόκειται να χρησιμοποιηθεί με όργανα που φέρουν το σήμα CE.

Ποιότητα του καλωδίου σήματος των στυπιοθλιπτών και των συνδέσμων.

Η Brooks κατά κανόνα προμηθεύει υψηλής ποιότητας καλώδια τα οποία πληρούν τις προδιαγραφές για πιστοποίηση CE.

Εάν η επιλογή του καλωδίου σήματος γίνει από σας πρέπει να χρησιμοποιήσετε καλώδιο το οποίο να φέρει εξωτερικά πλήρες πλέγμα και να παρέχει θωράκιση 100%.

Οι σύνδεσμοι τύπου "D" ή "Κυκλικοί" των καλωδίων, πρέπει να θωρακίζονται με μεταλλική θωράκιση. Εάν είναι εφαρμόσιμο, πρέπει να χρησιμοποιούνται μεταλλικοί στυπιοθλίπτες καλωδίων που να διαθέτουν ακροδέκτη σύνδεσης του πλέγματος του καλωδίου.

Το πλέγμα του καλωδίου πρέπει να συνδέεται στο μεταλλικό περίβλημα ή στον στυπιοθλίπτη και να θωρακίζεται και στα δύο άκρα κατά 360 μοίρες.

Η θωράκιση πρέπει να καταλήγει σε κάποιο ακροδέκτη γείωσης.

Οι σύνδεσμοι καρτών είναι μη-μεταλλικοί, τα καλώδια που χρησιμοποιούνται πρέπει να φέρουν πλέγμα θωράκισης 100% για να υπακούουν στην πιστοποίηση CE.

Η θωράκιση πρέπει να καταλήγει σε κάποιο ακροδέκτη γείωσης.

Για την διάταξη των ακροδεκτών: Παρακαλούμε αναφερθείτε στο εσώκλειστο Εγχειρίδιο Οδηγιών.

Italiano

Brooks Instrument
Neonstraat 3
6718 WX Ede
The Netherlands

Oggetto : **Addendum al manuale di istruzioni.**

Riferimento : **Certificazione CE dei misuratori termici di portata in massa**

Data : **Gennaio 1996.**

Questa strumentazione (elettrica ed elettronica) prodotta da Brooks Instrument, soggetta a marcatura CE, ha superato con successo le prove richieste dalla direttiva per la Compatibilità Elettromagnetica (Direttiva EMC 89/336/EEC).

E' richiesta comunque una speciale attenzione nella scelta dei cavi di segnale da usarsi con la strumentazione soggetta a marchio CE.

Qualità dei cavi di segnale e dei relativi connettori:

Brooks fornisce cavi di elevata qualità che soddisfano le specifiche richieste dalla certificazione CE. Se l'utente intende usare propri cavi, questi devono possedere una schermatura del 100%.

I connettori sia di tipo "D" che circolari devono possedere un guscio metallico. Se esiste un passacavo esso deve essere metallico e fornito di fissaggio per lo schermo del cavo.

Lo schermo del cavo deve essere collegato al guscio metallico in modo da schermarlo a 360° e questo vale per entrambe le estremità.

Lo schermo deve essere collegato ad un terminale di terra.

I connettori "Card Edge" sono normalmente non metallici. Il cavo impiegato deve comunque avere una schermatura del 100% per soddisfare la certificazione CE.

Lo schermo deve essere collegato ad un terminale di terra.

Per il corretto cablaggio dei terminali occorre fare riferimento agli schemi del manuale di istruzioni dello strumento.

Latviski

Neonstraat 3
6718 WX Ede
The Netherlands

Latviski

Visas Brooks (elektriskās/elektroniskās) iekārtas ar CE marķējumu ir veiksmīgi pārbaudītas saskaņā ar noteikumiem par elektromagnētisko saderību (EMC direktīva 86/336/EEK).

Taču īpaša uzmanība ir jāpievērš, izvēloties signāla kabeļus, kas tiks lietoti kopā ar iekārtām, kam piešķirts CE marķējums.

Signāla kabeļu, kabeļu uzgaļu un savienotāju kvalitāte:

Brooks piedāvā augstas kvalitātes kabeļus, kas atbilst CE marķēšanas noteikumiem.

Taču, ja vēlaties izmantot savu signāla kabeli, izvēlieties pilnībā ekranētu kabeli, kura ekrāna laukums ir vismaz 100%.

Visi izmantotie D tipa vai apaļas formas savienotāji jāekranē, izmantojot metāla ekrānu. Nepieciešamības gadījumā, lai iespilētu kabeļa ekranējumu, jāizmanto kabeļu uzgali.

Kabeļa ekranējums jāsavieno ar metāla čaulu vai uzgali, un ekranējumam abos kabeļa galos jābūt 360°.

Ekranējums jāsavieno ar zemējuma spaili.

Parasti drukāto shēmas plašu savienotāji nav izgatavoti no metāla. Lai atbilstu CE marķējuma prasībām, izmantotajiem kabeļiem jābūt ekranētiem, izmantojot ekrānu ar 100% laukumu.

Lietuviškai

Neonstraat 3
6718 WX Ede
The Netherlands

Visi „CE“ ženklų pažymėti „Brooks“ (elektros/elektroniniai) prietaisai sėkmingai testuoti pagal Elektromagnetinio suderinamumo reikalavimus (EMC direktyva 89/336/EEC). Tačiau reikia skirti ypatingą dėmesį, parenkant „CE“ ženklų pažymėtiems gaminiams naudojamus duomenų kabelius.

Duomenų kabelių, kabelių riebokščių ir kištukų kokybė:

„Brooks“ užtikrina puikios kokybės duomenų siuntimą kabeliu, atitinkantį „CE“ direktyvų reikalavimus.

Jei, nepaisant to, Jūs pageidaujate naudoti savo duomenų kabelį, rinkitės mažiausiai 100% padengtą, pilnai ekranuotą duomenų kabelį.

Jis turi būti ekranuotas bet koku panaudotu „D“ arba koaksialiniu jungiamuoju metalo šarvu. Jei įmanoma, kabelio dangą reikia suveržti metaliniais kabelio riebokščiais. Kabelio dangą reikia prisegti prie metalinės apsauginės dangos arba riebokščio, ir abiejuose galuose turi būti užtikrintas 360° ekranavimas.

Dangą reikia prijungti prie įžeminimo apkabos.

Ant kortelės spausdinti kištukai nemetaliniai, atitinka standartus. Tam, kad jie atitiktų „CE“ direktyvas, panaudoti kabeliai turi būti 100% ekranuoti.

Magyar

Brooks Instrument
Neonstraat 3
6718 WX Ede
The Netherlands

Valamennyi CE jellel ellátott Brooks (elektromos/elektronikus) berendezést sikeresen teszteltek az elektromágneses összeférhetőség követelményeinek megfelelően (EMC előírás 89/336/EEC). Azonban a CE jellel ellátott berendezésekhez használandó jelkábelek kiválasztására különös figyelmet kell szentelni.

A jelkábelek, kábel tömszelencék és csatlakozók minősége:

A Brooks kitűnő minőségű kábeleztést biztosít, ami eleget tesz a CE irányelvek követelményeinek. Ha azonban saját jelkábelét szeretné használni, egy legalább 100 %-ban burkolt, teljesen árnyékolt jelkábelrel válasszon.

Bármelyik felhasznált „D” vagy koaxiális csatlakozó fémvétezzettel kell legyen árnyékolva. Ha alkalmazható, a kábelburkolást fém kábel-tömszelencékkel kell összefogni. A kábelburkolást a fém védőburkolathoz vagy tömszelencéhez kell kapcsolni, és mindkét végén 360°-os árnyékoltságot kell biztosítani.

A burkolást egy földelőkapocshoz kell csatlakoztatni.

A kártyára nyomtatott csatlakozók nemfémek, mint szabványok. A felhasznált kábelek, ahhoz, hogy megfeleljenek a CE irányelveknek 100 % -os árnyékoltsággal kell rendelkezzenek.

Nederlands

Brooks Instrument
Neonstraat 3
6718 WX Ede
The Netherlands

Onderwerp : Addendum voor Instructie Handboek
Referentie : CE certificering voor Mass Flow Meters & Controllers
Datum : Januari 1996

Alle CE gemarkeerde elektrische en elektronische producten van Brooks Instrument zijn met succes getest en voldoen aan de wetgeving voor Electro Magnetische Compatibiliteit (EMC wetgeving volgens 89/336/EEC). Speciale aandacht is echter vereist wanneer de signaalkabel gekozen wordt voor gebruik met CE gemarkeerde producten.

Kwaliteit van de signaalkabel en kabelansluitingen:

- Brooks levert standaard kabels met een hoge kwaliteit, welke voldoen aan de specificaties voor CE certificering. Indien men voorziet in een eigen signaalkabel, moet er gebruik gemaakt worden van een kabel die volledig is afgeschermd met een bedekkingsgraad van 100%.
 - "D" of "ronde" kabelconnectoren moeten afgeschermd zijn met een metalen connector kap. Indien kabelwartels worden toegepast, moeten metalen kabelwartels worden gebruikt die het mogelijk maken het kabelscherp in te klemmen.
Het kabelscherp moet aan beide zijden over 360° met de metalen connectorkap, of wartel verbonden worden.
Het scherm moet worden verbonden met aarde.
 - "Card-edge" connectors zijn standaard niet-metallisch. De gebruikte kabels moeten volledig afgeschermd zijn met een bedekkingsgraad van 100% om te voldoen aan de CE certificering.
Het scherm moet worden verbonden met aarde.
Voor pin-configuraties a.u.b. verwijzen wij naar het bijgesloten instructie handboek.
-

Norsk

Brooks Instrument
Neonstraat 3
6718 WX Ede
The Netherlands

Vedrørende : Vedlegg til håndbok
Referanse : CE sertifisering av utstyr for massestrømsmåling og regulering
Dato : Januar 1996

Til den det angår

Brooks Instrument elektrisk og elektronisk utstyr påført CE-merket har gjennomgått og bestått prøver som beskrevet i EMC forskrift om elektromagnetisk immunitet, direktiv 89/336/EEC.

For å opprettholde denne klassifisering er det av stor viktighet at riktig kabel velges for tilkobling av det måletekniske utstyret.

Utførelse av signalkabel og tilhørende plugger:

- Brooks Instrument tilbyr levert med utstyret egnet kabel som møter de krav som stilles til CE-sertifisering.
- Dersom kunden selv velger kabel, må kabel med fullstendig, 100% skjerming av lederene benyttes.
"D" type og runde plugger og forbindelser må være utført med kappe i metall og kabelnipler må være utført i metall for jordat innfesting av skjermen. Skjermen i kabelen må tilknyttes metallet i pluggen eller nippelen i begge ender over 360°, tilkoblet elektrisk jord.
- Kort-kantkontakter er normalt utført i kunststoff. De tilhørende flatkabler må være utført med fullstendig, 100% skjerming som kobles til elektrisk jord på riktig pinne i pluggen, for å møte CE sertifiseringskrav.

For tilkobling av medleverte plugger, vennligst se håndboken som hører til utstyret.

Vennlig hilsen

Polski

Brooks Instrument
Neonstraat 3
6718 WX Ede
The Netherlands

Wszystkie urządzenia (elektryczne/elektroniczne) typu Brooks oznaczone znakiem CE były pomyślnie kontrolowane pod względem wymagań zgodności elektromagnetycznej (przepisy EMC 89/336/EEC).

Natomiast szczególną uwagę należy poświęcić na wybranie odpowiedniej kabli instalacyjnej do urządzeń oznaczonych znakiem CE.

Jakość kabli instalacyjnych, dławnic kablowych i złącz:

Brooks zapewnia okablowanie o wybitnej jakości, co odpowiada wymaganiom wytycznych CE.

Aczkolwiek Państwo zamierzacie stosować własny kabel instalacyjny, to należy wybrać odpowiedni kabel ekranowy, przykryty opłotem minimum w 100%.

Wszystkie stosowane złącze typu „D” lub kable koncentryczne powinny być przykryte opłotem z drutów miedzianych. Jeżeli da się zastosować, to należy osłony kablowe zgromadzić dławnicami kablowymi. Osłony kablowe należy podłączyć do dławnic lub do metalowych pokryw ochronnych, które na obydwu końcach muszą być zatłumione w 360%.

Pokrywy muszą być podłączone do złącz uziemionych.

Drukowane do kart złącze są niemetalowe, jako normy. Stosowane kable ekranowe mają być przykryte opłotem w 100%, ponieważ wymagania CE to przepisują, którym kable muszą odpowiadać.

Português

Brooks Instrument
Neonstraat 3
6718 WX Ede
The Netherlands

Assunto : Adenda ao Manual de Instruções

Referência : Certificação CE do Equipamento de Fluxo de Massa

Data : Janeiro de 1996.

O equipamento (eléctrico/electrónico) Brooks com a marca CE foi testado com êxito nos termos do regulamento da Compatibilidade Electromagnética (directiva CEM 89/336/EEC).

Todavia, ao seleccionar-se o cabo de sinal a utilizar com equipamento contendo a marca CE, será necessário ter uma atenção especial.

Qualidade do cabo de sinal, buchas de cabo e conectores:

A Brooks fornece cabo(s) de qualidade superior que cumprem os requisitos da certificação CE.

Se fornecerem o vosso próprio cabo de sinal, devem utilizar um cabo que, na sua totalidade, seja isolado com uma blindagem de 100%.

Os conectores tipo “D” ou “Circulares” devem ser blindados com uma blindagem metálica. Se tal for necessário, deve utilizarse buchas metálicas de cabo para o isolamento do aperto do cabo.

O isolamento do cabo deve ser ligado à blindagem ou bucha metálica em ambas as extremidades em 360°.

A blindagem deve terminar com a ligação à massa.

Os conectores “Card Edge” não são, em geral, metálicos e os cabos utilizados devem ter um isolamento com blindagem a 100% nos termos da Certificação CE..

A blindagem deve terminar com ligação à massa.

Relativamente à configuração da cavilha, queiram consultar o Manual de Instruções.

Română

Brooks Instrument
Neonstraat 3
6718 WX Ede
The Netherlands

Fiecare aparat Brooks (electric/electronic), pevăzut cu inscripția CE a fost testat cu succes potrivit cerințelor compatibilității electromagnetice (standardul EMC 89/366/EEC).
Însă o atenție deosebită trebuie acordată la alegerea cablurilor de semnal pentru aparatura prevăzută cu inscripția CE.

Calitatea cablurilor de semnal, a glandelor și a conexiunilor:

Brooks asigură a cablare de calitate excelentă, care satiface cerințele standardelor CE.
Însă, în cazul în care doriți să utilizați un cablu de semnal propriu, trebuie să alegeți un cablu de semnal izolat în proporție de cel puțin 100%, având o ecranare integrală.

Orice conexiune de tip „D” sau coaxială utilizată trebuie să fie ecranată cu armătură metalică. În cazul în care acesta este utilizabilă, învelișul cablului trebuie strâns cu glande metalice. Este necesară fixarea învelișului cablului la învelișul metalic sau la glande, în așa fel încât la ambele capete ale cablului să asigure o ecranare de 360°.
Învelișul trebuie conectat la o clemă de pământare.

Conform standardelor, conexiunile imprimate pe cartele nu sunt considerate conexiuni metalice. În vederea conformării standardelor CE, cablurile utilizate trebuie să asigure o ecranare de 100%.

Slovensko

Brooks Instrument
Neonstraat 3
6718 WX Ede
The Netherlands

Vse (električne/elektronske) naprave Brooks z zaznamovanjem CE so uspešno testirane primerno zahtevam elektromagnetne kompatibilnosti (EMC predpis 89/336/EEC).
Medtem ko mora se posvetiti posebna pozornost za izbiro signalnih kabl, ki se uporabijo naprave z zaznamovanjem CE.

Kakovost signalnih kabl, kablskih tulcev in priključkov:

Brooks zavaruje kabliranje odlične kakovosti, kar zadoščuje zahtevam CE direktiv.
Če medtem ko želite uporabiti svoj signalni kabel, izbirajte signalni kabel, ki je vsaj v 100 % zaviti in popolnoma zasenčeni signalni kabel.

Kateri koli „D” ali koaks priključek mora bit zasenčen s kovinsko opremo. Če je uporabivo, kablško oblogo je potrebno zajemati skupaj s kovinskimi tulci za kable. Kablško oblogo je potrebno povezovati s kovinsko zaščitno oblogo ali s tulci in na obeh koncih je potrebno da zavaruje senco od 360°.
Oblogo je treba spojiti z ozemljitvijo.

Priključki tiskani na kartico so nekovinski, kot standardi, da ustrezajo direktivam CE, uporabljeni kabli morajo razpolagati s senco od 100 %.

Slovensky

Brooks Instrument
Neonstraat 3
6718 WX Ede
The Netherlands

Všetky zariadenia (elektrické/elektronické) Brooks vybavené so značením CE boli úspešne testované podľa požiadaviek elektromagnetickej zhody (EMC predpis 89/336/EEC).

Avšak pri voľbe signálových káblov k prístrojom vybaveným značkou CE sa musí zaobchádzať s veľkou opatrnosťou.

Kvalita signálových káblov, káblových izolačných krabic a prípojok:

Brooks zabezpečuje vynikajúcu kábeláž, ktoré vyhovujú požiadavkám smernice CE.

Ale ak by ste chceli používať vlastné signálové káble, vyberte si aspoň do 100 % pokrytý úplne tieneny signálový kábel.

Ktorákoľvek použitá „D” prípojka alebo koaxiálna prípojka musí byť tienená kovovým krytom. Ak je možné, káblové pokrytie sa musí združiť izolovanými krabicami pre káblov. Pokrytie káblov sa musia pripojiť k ochrannému krytiu alebo izolačnými krabicami, a na oboch koncoch sa musí zabezpečiť 360°-ové tienenie.

Krytie sa musí pripojiť uzemňovaciemu uzlu.

Prípojky tlačené na karty sú drahé kovy, podľa noriem. Aby vyhoveli požiadavkám smernice CE, použité káble musia disponovať s 100 %-ným tienením.

Suomi

Brooks Instrument
Neonstraat 3
6718 WX Ede
The Netherlands

Asia : Lisäys Käyttöohjeisiin

Viite : Massamäärämittareiden CE sertifiointi

Päivämäärä : Tammikuu 1996

Brooksin CE merkillä varustetut sähköiset laitteet ovat läpäissyt EMC testit (direktiivi 89/336/EEC).

Eriyistä huomiota on kuitenkin kiinnitettävä signaalikaapelin valintaan.

Signaalikaapelin, kaapelin läpiviennin ja liittimen laatu

Brooks toimittaa korkealaatuisia kaapeleita, jotka täyttävät CE sertifikaatin vaatimukset. Hankkiessaan signaalikaapelin itse,

olisi hankittava 100%:sti suojattu kaapeli.

“D” tai “Circular” tyyppisen liittimen tulisi olla varustettu metallisuojoilla. Mikäli mahdollista, tulisi käyttää metallisia kaapeliliittimiä kiinnitettäessä suoja.

Kaapelin suoja tulisi olla liitetty metallisuojaan tai liittimeen molemmissa päissä 360°:n matkalta.

Suojan tulisi olla maadoitettu.

“Card Edge Connector”it ovat standarditoimituksina ei-metallisia. Kaapeleiden täytyy olla 100%: sesti suojattuja jotta ne olisivat CE sertifikaatin mukaisia.

Suoja on oltava maadoitettu.

Nastojen liittäminen; katso liitteenä oleva manuaali.

Ystävällisin terveisin,

Svensk

Brooks Instrument
Neonstraat 3
6718 WX Ede
The Netherlands

Subject : Addendum to the Instruction Manual

Reference : CE certification of Mass Flow Equipment

Date : January 1996

Brooks (elektriska / elektronik) utrustning, som är CE-märkt, har testats och godkänts enligt gällande regler för elektromagnetisk kompatibilitet (EMC direktiv 89/336/EEC).

Speciell hänsyn måste emellertid tas vid val av signalkabel som ska användas tillsammans med CE-märkt utrustning.

Kvalitet på signalkabel och anslutningskontakter:

Brooks levererar som standard, kablar av hög kvalitet som motsvarar de krav som ställs för CE-godkännande.

Om man använder en annan signalkabel ska kabeln i sin helhet vara skärmad till 100%.

“D” eller “runda” typer av anslutningskontakter ska vara skärmade. Kabelgenomföringar ska vara av metall alternativt med metalliserad skärmning.

Kabelns skärm ska, i bada ändrar, vara ansluten till kontakternas metallkåpor eller genomföringar med 360 graders skärmning.

Skärmen ska avslutas med en jordförbindelse.

Kortkontakter är som standard ej metalliserade, kablar som används måste vara 100% skarmade för att överensstämna med CE-certifieringen.

Skärmen ska avslutas med en jordförbindelse.

För elektrisk anslutning till kontaktstiften hänvisas till medföljande instruktionsmanual.

Addendum

April 5, 2004

Attach to the following publications:

X-5850EM, December 1998, Issue 3

X-5964, dated April 1996, Issue 2

X-5866, dated April 1998, Issue 2

X-5866RT, dated May 1998, Issue 2

Brooks® Thermal Mass Flow Common Body Dimensions

Issue

Dimensional drawings appearing in the above listed instruction manuals do not depict current body fitting configurations being offered.

Action

The latest revision VCR body fitting configurations offer a modified mounting configuration adding the SEMI standard mounting hole configuration and only one (1) of the legacy Brooks mounting holes.

When specifying any of the models listed below, please refer to the attached Figures A-1 thru A-2 for mounting holes and Downport configuration information:

5850EMF

5964D

5866

5866RT

Addendum

April 5, 2004

Attach to the following publications:

X-5850EM, December 1998, Issue 3

X-5964, dated April 1996, Issue 2

X-5866, dated April 1998, Issue 2

X-5866RT, dated May 1998, Issue 2

Brooks® TMF Common Body Dimensions

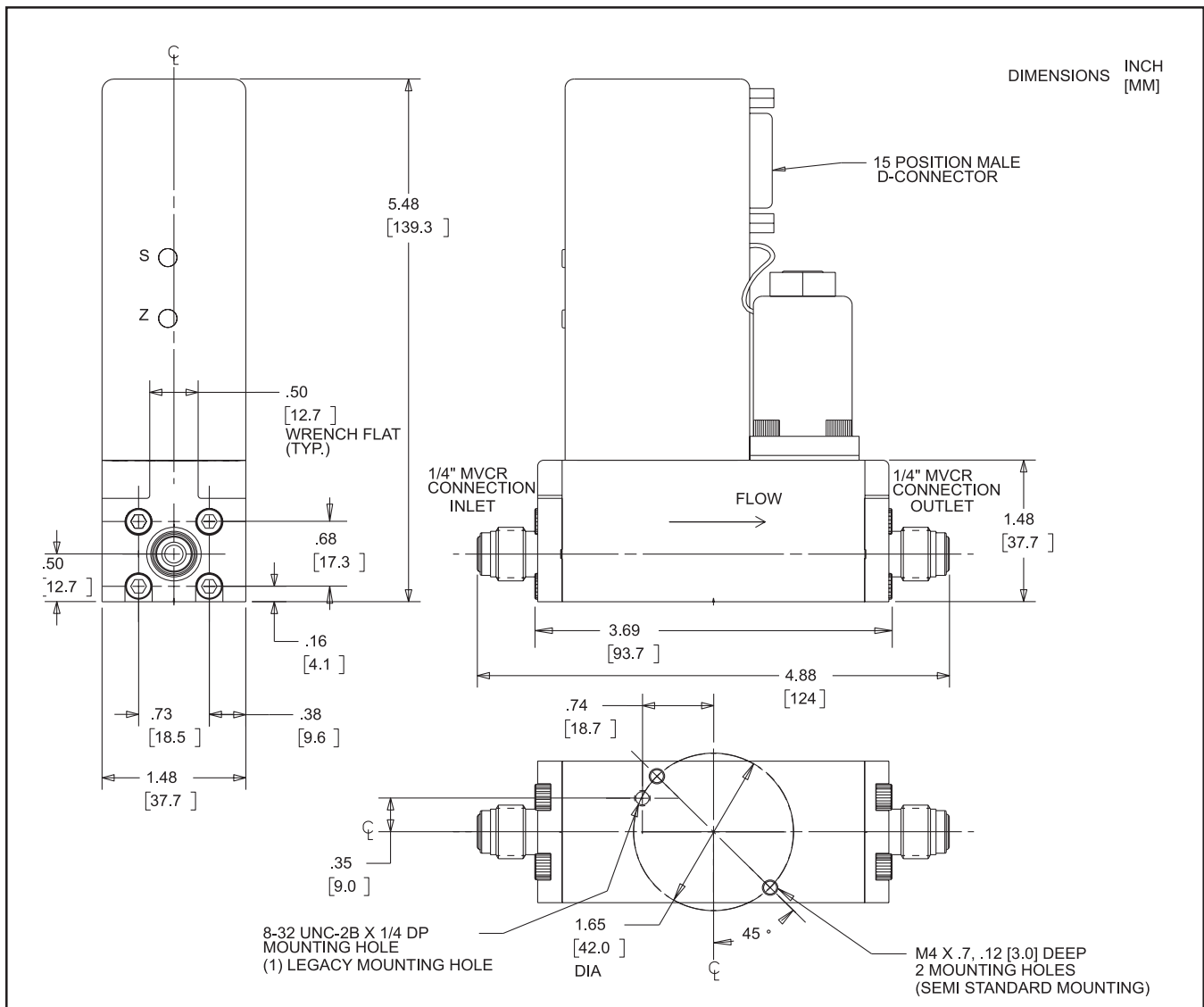

Figure A-1 Typical MFC/MFM Dimensional Drawing with VCR Fittings for Models 5850EMF, 5964D, 5866 and 5866RT.

Addendum

April 5, 2004

Attach to the following publications:

X-5850EM, December 1998, Issue 3

X-5964, dated April 1996, Issue 2

X-5866, dated April 1998, Issue 2

X-5866RT, dated May 1998, Issue 2

Brooks® TMF Common Body Dimensions

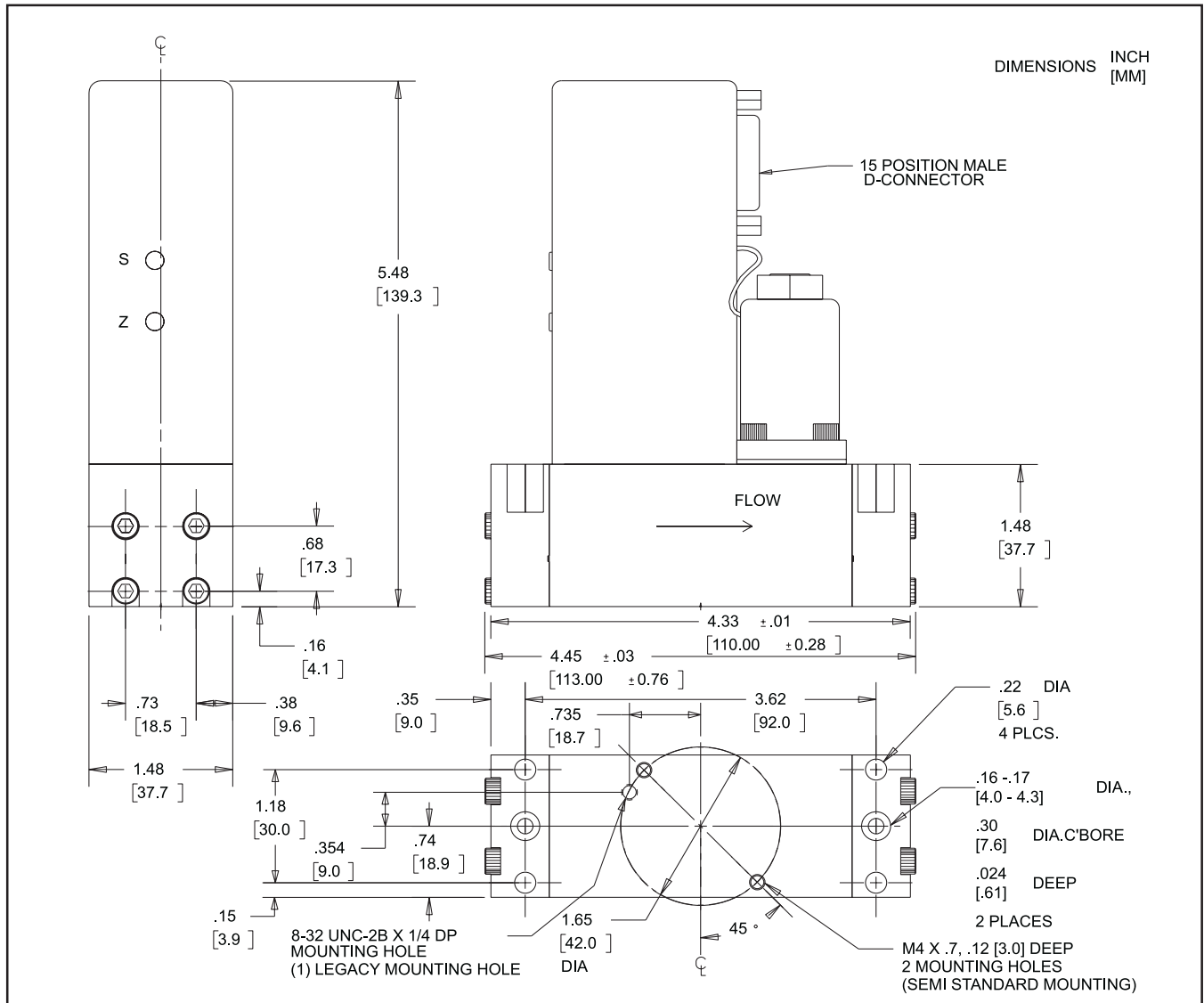

Figure A-2 Typical Downport MFC/MFM Dimensional Drawing Fittings for Models 5850EMF, 5964D, 5866 and 5866RT.

LIMITED WARRANTY

Seller warrants that the Goods manufactured by Seller will be free from defects in materials or workmanship under normal use and service and that the Software will execute the programming instructions provided by Seller until the expiration of the earlier of twelve (12) months from the date of initial installation or eighteen (18) months from the date of shipment by Seller. Products purchased by Seller from a third party for resale to Buyer ("Resale Products") shall carry only the warranty extended by the original manufacturer.

All replacements or repairs necessitated by inadequate preventive maintenance, or by normal wear and usage, or by fault of Buyer, or by unsuitable power sources or by attack or deterioration under unsuitable environmental conditions, or by abuse, accident, alteration, misuse, improper installation, modification, repair, storage or handling, or any other cause not the fault of Seller are not covered by this limited warranty, and shall be at Buyer's expense.

Goods repaired and parts replaced during the warranty period shall be in warranty for the remainder of the original warranty period or ninety (90) days, whichever is longer. This limited warranty is the only warranty made by Seller and can be amended only in a writing signed by an authorized representative of Seller.

BROOKS LOCAL AND WORLDWIDE SUPPORT

Brooks Instrument provides sales and service facilities around the world, ensuring quick delivery from local stock, timely repairs and local based sales and service facilities.

Our dedicated flow experts provide consultation and support, assuring successful applications of the Brooks flow measurement and control products.

Calibration facilities are available in local sales and service offices. The primary standard calibration equipment to calibrate our flow products is certified by our local Weights and Measures Authorities and traceable to the relevant international standards.

START-UP SERVICE AND IN-SITU CALIBRATION

Brooks Instrument can provide start-up service prior to operation when required.

For some process applications, where ISO-9001 Quality Certification is important, it is mandatory to verify and/or (re)calibrate the products periodically. In many cases this service can be provided under in-situ conditions, and the results will be traceable to the relevant international quality standards.

CUSTOMER SEMINARS AND TRAINING

Brooks Instrument can provide customer seminars and dedicated training to engineers, end users and maintenance persons. Please contact your nearest sales representative for more details.

HELP DESK

In case you need technical assistance:

- Americas ☎ 1-888-554-FLOW
- Europe ☎ +(31) 318 549 290 Within Netherlands ☎ 0318 549 290
- Asia ☎ +011-81-3-5633-7100



Due to Brooks Instrument's commitment to continuous improvement of our products, all specifications are subject to change without notice.

TRADEMARKS

- BrooksBrooks Instrument, LLC
- Freon TF E.I. DuPont de Nemours & Co.
- HastelloyHaynes International
- Kalrez DuPont Dow Elastomers
- Teflon E.I. DuPont de Nemours & Co.
- Viton DuPont Performance Elastomers

Brooks Instrument
 407 West Vine Street
 P.O. Box 903
 Hatfield, PA 19440-0903 USA
 T (215) 362-3700
 F (215) 362-3745
 E-Mail BrooksAm@EmersonProcess.com
www.BrooksInstrument.com

Brooks Instrument
 Neonstraat 3
 6718 WX Ede, Netherlands
 T 31-318-549-300
 F 31-318-549-309
 E-Mail BrooksEu@EmersonProcess.com

Brooks Instrument
 1-4-4 Kitasuna Koto-Ku
 Tokyo, 136-0073 Japan
 T 011-81-3-5633-7100
 F 011-81-3-5633-7101
 E-Mail BrooksAs@EmersonProcess.com